

Guided Wave Radar Level Meter



Guided Wave Radar Level Meter

User Manual

VER.1.0

WARNING

◆ Electrostatic protection measurement

This instrument contains electronic components sensitive to electrostatic discharge. Therefore, appropriate and effective electrostatic protection measurement should be taken when disassembling or installing the internal circuit boards or components. Please follow the principles below:

1. Disconnect the power supply of the instrument
2. Before touching, disassembling, installing, or adjusting the printed circuit board or its internal components, personnel should wear an anti-static ring or use other safe and reliable grounding methods to ensure rapid and smooth discharge of static electricity.
3. The printed circuit board must be transported and stored in a conductive packaging bag or other conductive container until it is taken out from the electrostatic protective package for on-site installation. Replaced printed circuit boards must be immediately placed in a container with electrostatic protection function and should not be randomly placed for transportation or storage.

◆ Transportation and storage

The instrument is packaged in cardboard or wooden boxes. Handle with care during transportation and avoid rough loading and unloading. The storage location should be rainproof, moisture-proof, and free from mechanical vibration or impact.

◆ Unpacking and inspection

After unpacking, carefully inspect the instrument according to the packing list. If any errors, shortages, or damages are found, please immediately contact our company or the local agent.

◆ Instrument installation and commissioning

1. Read the instruction manual carefully and strictly follow the relevant requirements for installation and commissioning.
2. Ensure reliable grounding of the instrument.
3. After the instrument wiring is completed, ensure good sealing of the outlet and prevent water accumulation in the cable conduit.
4. After the instrument commissioning is completed, tighten the instrument cover.

◆ Environmental protection

The packaging material of this instrument meets environmental requirements. After unpacking, please dispose of it through local recycling institutions. When the instrument becomes obsolete, it should be disposed of by electronic processing units.

CONTENTS

1	PROFILE	4	6.4	HART Communicator	26
1.1	Principle	4	7	INSTRUMENT DISPLAY UNIT PARAMETER SETUP	28
1.2	Features and Advantages	4	7.1	Menu Structure Diagram	28
1.3	Examples of Application	6	7.2	Basic Setting Method	29
2	STRUCTURE SIZE	7	7.3	Main Interface Introduction	30
3	INSTALLATION GUIDE	12	7.4	Echo Quick View Interface	31
3.1	Unpacking and Inspection	12	7.5	[Quick Setup] Menu	32
3.2	Installation	12	7.6	[Basic Setup] Menu	36
3.3	Precautions	13	7.7	[Display] Menu	37
4	ELECTRICAL CONNECTION	16	7.8	[System] Menu	38
4.1	Supply Voltage	16	7.9	[Security] Menu	39
4.2	Connecting Cables and Installation	16	7.10	[Diagnostics] Menu	40
4.3	Shielded Cables and Grounding	17	7.11	[Information] Menu	41
4.4	Cable Parameter	17	7.12	[Record Curve] Menu	41
4.5	Output Parameter	17	7.13	[Communication] Menu	41
5	WIRING INSTRUCTION	18	7.14	[Linearization]	41
6	INSTRUMENT DEBUGGING TYPE	23	8	DEBUGGING ACCEPTANCE CONFIRMATION	41
6.1	Instrument LCD Display Unit	24		Common Fault Handling	42
6.2	Instrument Remote LCD Display Unit	24		Common Substances Dielectric Constant	43
6.3	Upper Computer Debugging	26			

1 PROFILE

1.1 Principle

The guided wave radar level meters are electromagnetic wave ranging systems based on the principle of time travel. The 1GHz low-power electromagnetic wave signal emitted by the instrument probe propagates at the speed of light along the detection component (probe rod or detection cable). When electromagnetic waves come into contact with the surface of the measured substance, they are reflected back due to a sudden change in dielectric constant. The reflected electromagnetic wave propagates along the detection component and returns to the instrument probe. The time interval between the emission and reception of electromagnetic waves is directly proportional to the distance between the instrument probe and the measured medium, and thus the distance between the instrument probe and the surface of the measured medium can be calculated.

1.2 Features and Advantages

Comparison with non-similar products

- ◆ Compared to ultrasonic instruments, guided wave radar level meters are not affected by pressure changes, vacuum, temperature changes, inert gases, smoke, steam, and other environmental factors, and their measurement results are stable and reliable. It can work in an environment with a maximum temperature of 400 °C and a maximum pressure of 40Mpa.
- ◆ Compared to non-contact radar level meters, electromagnetic wave signals from guided wave radar level meters propagate along detection components (rods or cables), so they are less affected by factors such as water vapor and dust in the measurement environment. The microwave signal propagated along the detection component still has the same reflection performance on the fluctuating interface, so it is almost unaffected by material fluctuations. The contact measurement method enhances the signal reflection ability and can measure media with lower dielectric constants. The contact measurement method makes the signal reflection more reliable, thus avoiding wave loss.
- ◆ Compared to capacitive level meters, they do not require empty or full tank calibration and are directly used, making on-site operation simple. The measurement results are not affected by changes in dielectric constant. Reliable measurements can also be made when the tested medium is a mixture with unclear composition or composition ratios that change at any time.

- ◆ Compared to level meters such as magnetic flip plates, magnetostriction, heavy hammers, steel strips, or floating balls, guided wave radar level meters do not rely on mechanical motion for measurement, have no moving parts, have high reliability, and long service life.

Comparison with similar products

- ◆ The instrument employs equivalent sampling pulse ranging technology, enhancing signal resolution and sensitivity. This provides the instrument with advantages such as high accuracy, superior measurement sensitivity, and rapid refresh speed.
- ◆ The instrument LCD operation unit is a 128 * 64 graphics dot matrix LCD, which supports complex operation functions.Reduce the difficulty of on-site instrument operation and maintenance workload.
- ◆ The LCD display unit can be connected to the outside for 25 meters, forming a tank side operation unit. Reduce the risk and labor intensity of daily inspection work for instruments in high-risk areas such as large tanks, high temperature, high pressure, and toxicity.
- ◆ A remote operation unit based on HART communication, capable of external connections up to 1000 meters, compensating for the communication distance limitations of traditional tank-side display operation units.
- ◆ A radar-specific HART communicator with a waveform display function. By utilizing this communicator, radar waveforms can be directly observed in the central control room for debugging, significantly reducing the risks and labor intensity associated with on-site debugging.
- ◆ The Liquid Guided Wave Radar Meter features a unique probe design that enhances signal strength, reduces blind spots, and minimizes probe size, allowing for a smaller on-site opening.
- ◆ The Solid Guided Wave Radar Meter, featuring a unique solid guided wave detection sensor design, can withstand greater tensile forces, reducing the risk of cable detachment on-site.
- ◆ The Guided Wave Radar Level Meter supports a wide range of signal communication protocols, including HART, 4...20mA, RS485, IIC, and Modbus.
- ◆ Instrument functions and sensors can be customized according to the operational characteristics of the customer's industry and specific on-site conditions.

1.3 Examples of Application

Liquid level measurement

- ◆ Liquid Guided Wave Radar Level Meter is an ideal solution for noncorrosive liquid level measurement. The unique probe design makes the measurement signal stronger, resulting in more reliable and stable measurement results. The unique probe design allows for smaller blind spots for measuring smaller containers. The unique probe design makes the probe size smaller, making the on-site opening size smaller and more convenient for on-site installation. The detection component of coaxial structure is very suitable for measuring low viscosity liquids with small dielectric constants. The detection components of coaxial structures are also very suitable for applications with high measurement accuracy requirements. The measured results are independent of the density, temperature, pressure, foam, dielectric constant and other characteristics of the measured medium.

Solid level measurement

- ◆ Solid Guided Wave Radar Level Meter is designed for solid-state measurement. Sensors with larger size can withstand greater tensile forces. Both the probe rod and probe cable have a bold design, which is more resistant to wear and tear. Due to the low tension and wear of fine particles and powdered solids on the cable, has good performance in measuring the level of fine particles and powdered solids. The unique anti loosening design of radar minimizes the risk of solid measurement cables falling.

Acid alkali level measurement

- ◆ Corrosive Liquid Guided Wave Radar Level Meter is designed for measuring corrosive liquids. The probe and instrument flanges are fully covered with PFA material. It is an ideal solution for measuring corrosive liquids.

Liquid level measurement of food processing or pharmaceutical containers

- ◆ Corrosive Liquid Guided Wave Radar Level Meter is also an ideal choice for liquid level measurement in food processing and pharmaceutical containers. The detection component is fully coated with food safety grade materials PFA or PTFE, which fully meets food hygiene and safety requirements.

Liquid level measurement using riser and bypass methods

- ◆ The use of risers and bypass pipes can solve the impact of mixing fan blades on guided wave detection components, which is often seen in chemical reaction vessels, such as the petrochemical industry. Of course, in this measurement environment, guided wave radar measurement has many advantages. Risers and bypass pipes can enhance the strength of the signal received by guided wave radar. The side connection opening of the bypass pipe, as well as the sediment or corrosive substances inside the tank, will not affect the measurement results. The product can be measured in environments up to 400 °C, and even standard products can be measured at 150 °C.

2 Structure Size

Single chamber housing size note: The values marked in [] are in inches, and the rest are in millimeters.

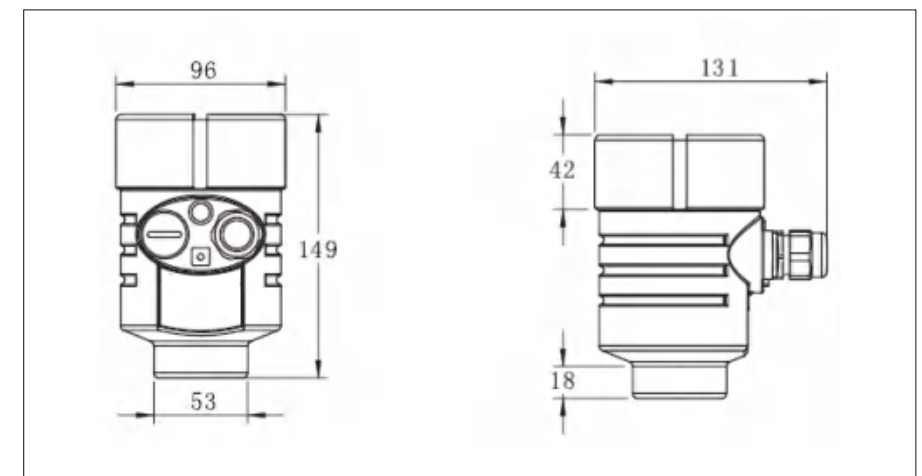

Dual chamber housing size note:The values marked in [] are in inches, and the rest are in millimeters.

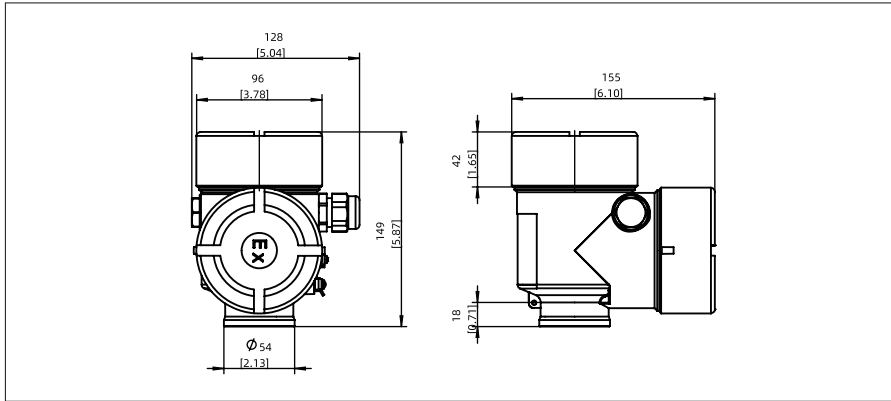

(2)Liquid Level and Interface Meter Liquid Measurement(dual cable type)

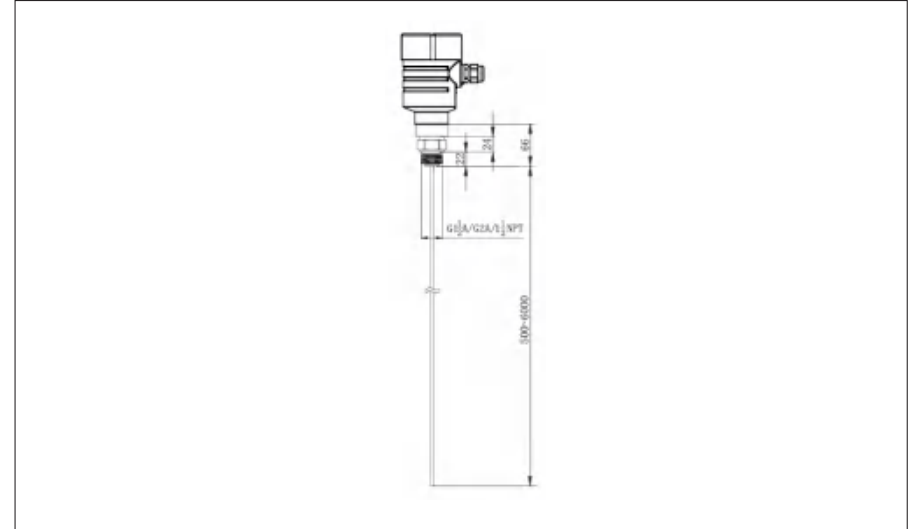

Instrument size note:The values marked in [] are in inches, and the rest are in millimeters.

(1)Liquid Level and Interface Meter Liquid Measurement

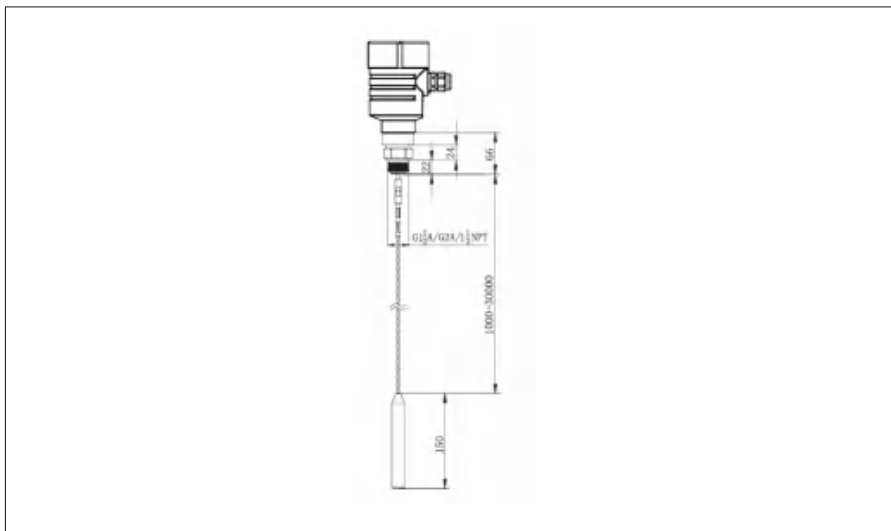

(3)Liquid Level and Interface Meter Liquid Measurement(coaxial)

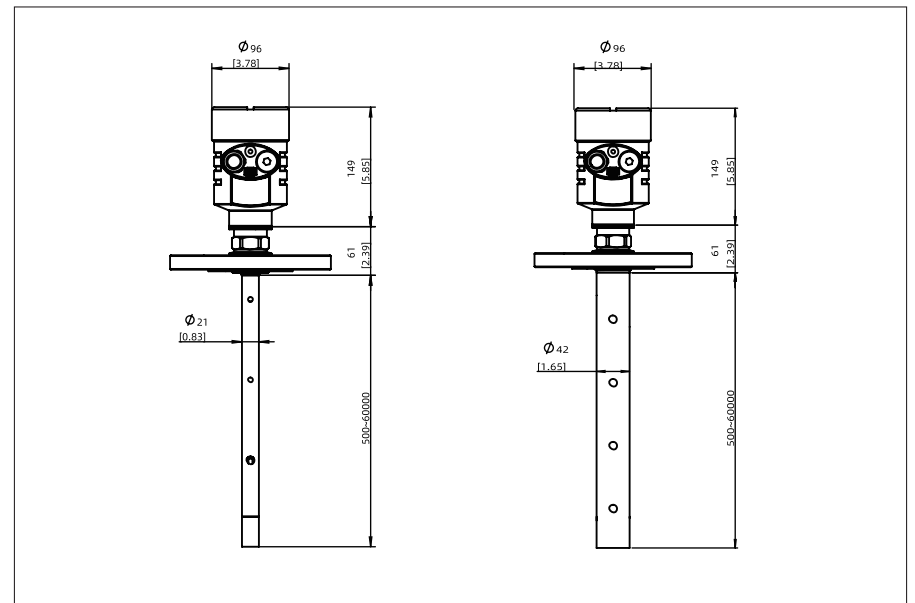

(4) Solid Level and Interface Meter Solid Measurement(cable type)

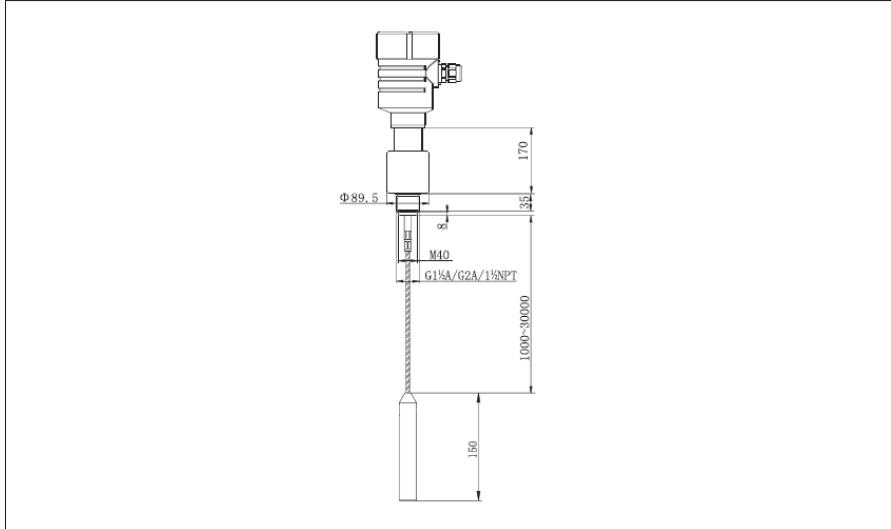

(6) Corrosive Liquid Level and Interface Meter Corrosive Liquid Measurement

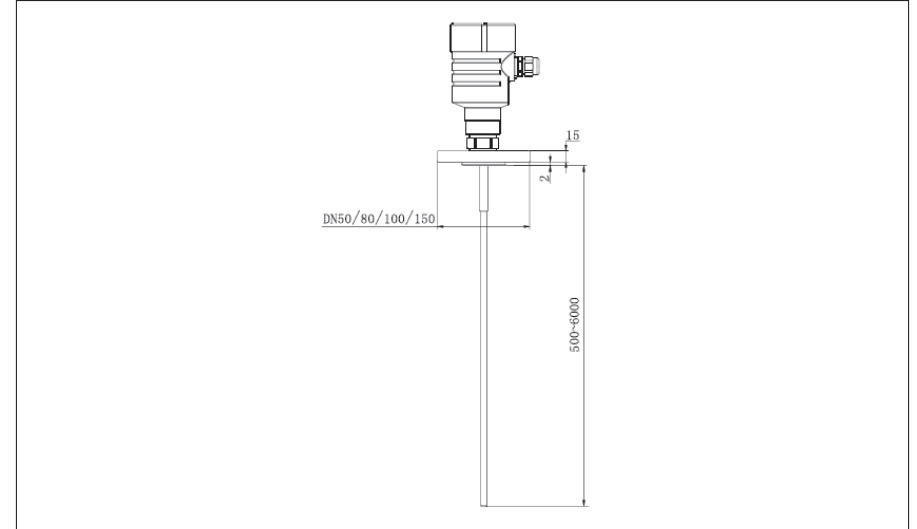

(5) Solid Level and Interface Meter Solid Measurement(rod type)

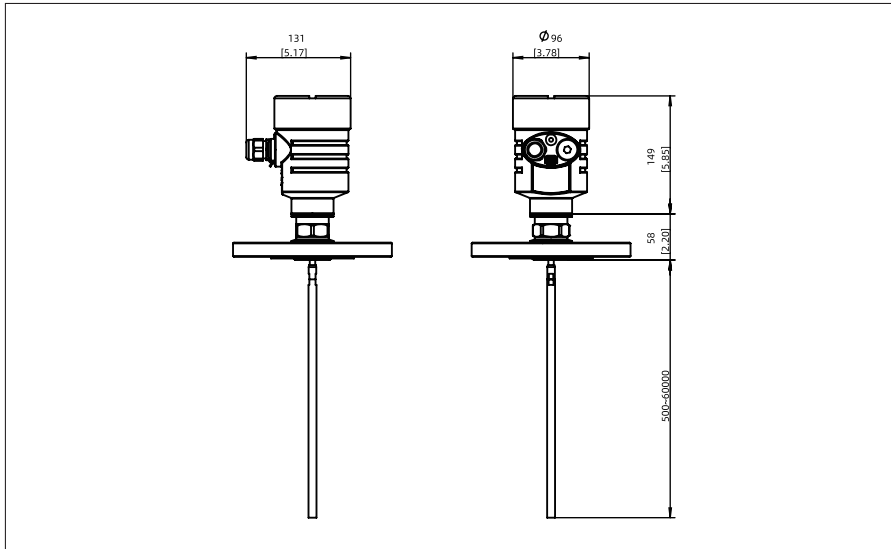

(7) High Temperature and High Pressure Level and Interface Meter

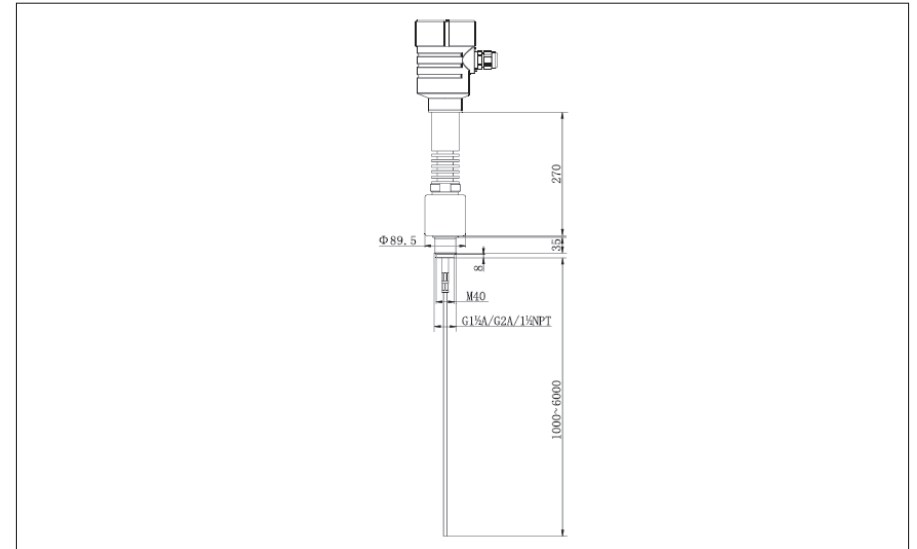

3 INSTALLATION GUIDE

3.1 Unpacking and Inspection

3.1.1

The instruments are packaged in cardboard or wooden boxes, and should be carefully transported during transportation. Rough loading and unloading is not allowed, and the storage location should meet the following conditions:

- ◆ Rainproof and moisture-proof; Not subject to mechanical vibration or impact; Temperature range $-20\text{ }^{\circ}\text{C}$ to $75\text{ }^{\circ}\text{C}$;
- ◆ The relative humidity shall not exceed 80%; The environment does not contain corrosive gases.

3.1.2

Carefully open the packaging box and remove the filling inside. Carefully check all items on the packing list, including instrument model and quantity, installation accessories, instructions, etc. If any errors, shortages, or damages are found, please contact our company or local agent immediately. The packaging box is not retracted.

3.2 Installation

3.2.1 Basic requirements

Ensure that the detection cables and rods do not come into contact with internal obstacles throughout the entire range. Therefore, during installation, efforts should be made to avoid facilities inside the tank, such as ladders, limit switches, heating equipment, brackets, etc.

The highest material level must not enter the measurement blind zone.

The instrument must maintain a certain distance from the tank wall to prevent contact between the detection component (probe rod or detection cable) and the pipe wall from affecting the measurement results.

Prevent the detection component (probe rod or detection cable) from coming into contact with the feed stream. The installation of the instrument should be as vertical as possible to the detection cable or rod and the surface of the measured medium.

Instruments installed in explosion-proof areas must comply with the installation regulations for explosion-proof hazardous areas. The intrinsically safe housing is made of stainless steel or anti-static plastic. Intrinsically safe instruments can be installed in places with explosion-proof requirements, and the instruments must be grounded.

3.2.2 Measuring range

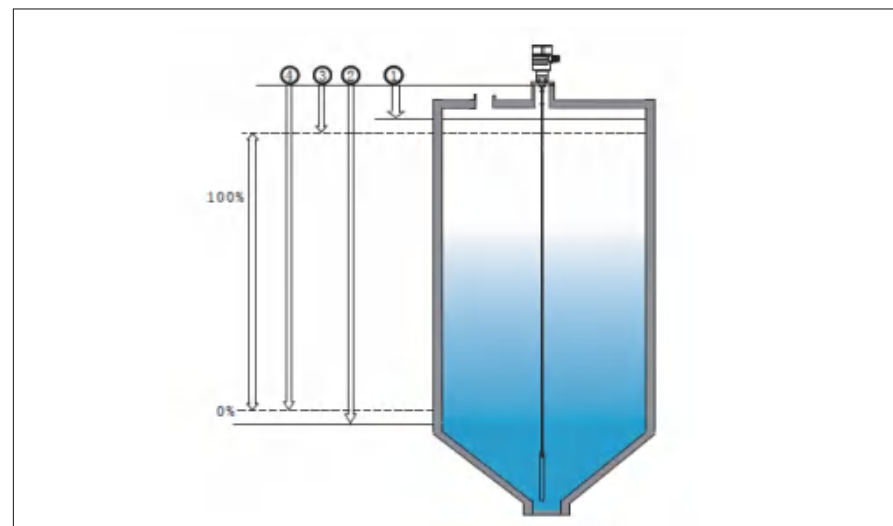

① Blind zone range ② Cable length ③ High range ④ Low range

Note: The reference plane for measurement is the sealing surface of the thread; When the material enters the blind area, the instrument cannot measure the material level normally; The heavy hammer part at the bottom of the detection cable cannot be used as the measuring range.

3.3 Precautions

3.3.1 Pressure

If the tested container is under high pressure or vacuum, check whether the sealing material is suitable for sealing the tested substance inside the container before use. And check whether the maximum allowable pressure of the instrument can meet the internal pressure requirements of the container.

3.3.2 Installation position

The installation of the guided wave radar level meter requires ensuring that the detection cable and detection rod do not come into contact with any equipment or container walls. If necessary, the bottom of the detection cable can be fixed. If the above conditions cannot be guaranteed, using coaxial detection components can enable guided wave radar to operate normally in this environment.

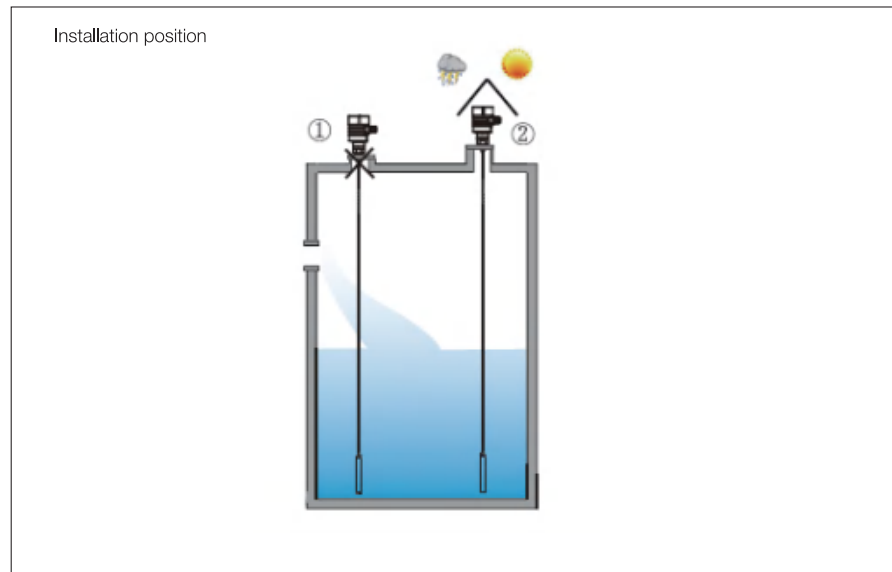

When installing a cable or pole type guided wave radar, the cable and pole must be at least 30cm away from the container equipment and the container wall.

The installation of the guided wave radar meter should be as flush as possible with the tank top. If the on-site installation method is using a riser, the riser should be as short as possible.

When the instrument is installed on a vertical pipe with a length greater than 20cm or a diameter greater than 20cm or a distance less than 30cm from the pipe wall, it is necessary to establish a false echo curve on the instrument to ensure its normal operation. It is also recommended to use coaxial detection components as much as possible under these installation conditions to avoid the impact of this unsuitable installation position.

3.3.3 Bottom fixation

For the installation of the detection cable, due to the movement or agitation of materials during the measurement process, the detection cable may touch the container wall, resulting in abnormal measurement. In this housing, the detection cable can be fixed at the bottom. The heavy hammer at the bottom of the detection cable has an M12 threaded hole. The bottom of the cable and the bottom of the container can be connected and fixed by connecting some fixing rings or brackets through this thread. When fixing the bottom of the detection cable, ensure that the cable is not excessively tensioned to prevent the cable from bearing too much tension.

It is important to avoid situations where the bottom of the cable and the bottom of the container come into contact and loosen at times, as this can cause unstable echo signals at the bottom and result in misjudgment by the instrument. It must be ensured that the cable is reliably connected to the bottom of the container or completely detached from the bottom of the container.

3.3.4 Installation of bypass pipe

The guided wave radar level meter can be installed on bypass pipe with a diameter of >25mm. It is necessary to ensure that the detection cable or detection rod does not contact the bypass pipe wall during operation. The guided wave radar is an ideal replacement for magnetic flip plates and magnetostrictive instruments, as it has no moving parts, making measurement more reliable and has a longer lifespan. Not affected by density fluctuations, easy to install.

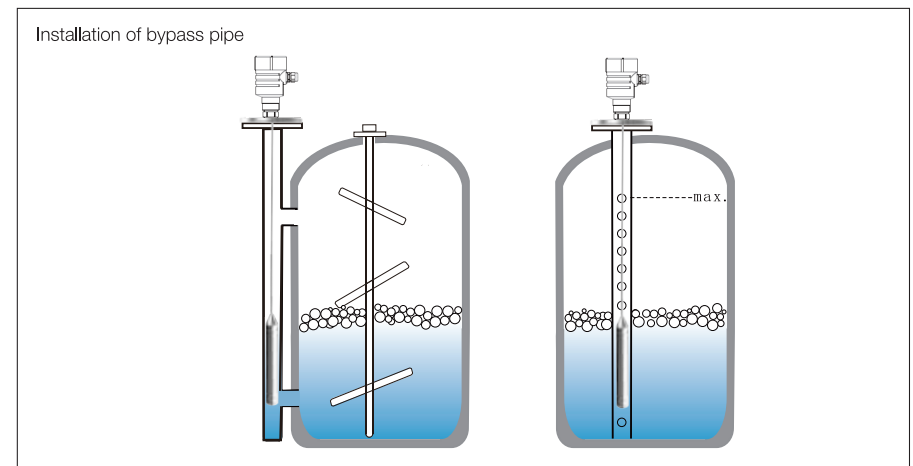

3.3.5 Moisture-proof

For instruments installed outdoors or in damp rooms and on refrigerated or heated tanks, in order to prevent moisture, the waterproof joint at the inlet port of the instrument housing should be tightened, and the cable should be bent downwards at the inlet port.

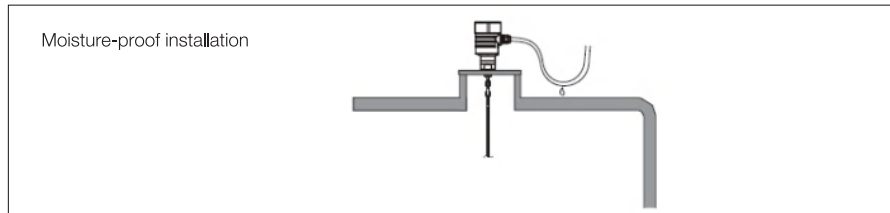

4 ELECTRICAL CONNECTION

4.1 Supply Voltage

4...20mA/HART(Two wire system): The instrument power supply and current signal share a two core cable, and the specific supply voltage range can be found in the technical data. For Intrinsically safe, a safety barrier must be added between the power supply and the instrument.

4...20mA/HART(Four wire system): The instrument power supply and current signal each use a two core cable, and the specific power supply voltage range can be found in the technical data.

The current output of standard instruments can be grounded, while the current output of explosion-proof instruments must be floating. Usually, grounding can be connected to the grounding point of the tank. If it is a plastic tank, it should be grounded nearby.

4.2 Cable Connection and Installation

4...20mA/HART(Two wire system): The cable should be shielded with an outer diameter between 6-12mm to ensure the sealing of the cable inlet. It is recommended to use standard two core cables for wiring, and the recommended cable model is Belden 3076F.

4...20mA/HART(Four wire system): The cable should be shielded with an outer diameter between 6-12mm, and a cable with a dedicated ground wire should be used.

4.3 Shielded Cables and Grounding

Both ends of the shielded cable should be grounded.

The grounding terminal inside the instrument housing is used for cable shielding or grounding of a dedicated grounding wire. The external grounding terminal of the instrument housing is used to complete the grounding between the instrument and the on-site ground.

If there is grounding current, the shielding end of the shielded cable on the side away from the instrument must be grounded through a ceramic capacitor (such as InF 1500V) to suppress low-frequency grounding current while still preventing high-frequency interference signal.

4.4 Cable Parameter

Suitable for cross-sectional area of 2.5mm² Wire.

4.5 Output Parameter

Output signal: 4~20mA(HART).

Resolution ratio: 1.6uA.

Fault signal: Unchanged current, 20.5mA, 22mA, 3.9mA.

Four-wire load resistance: 500 ohms max.

Damping time: 0~90S optional.

Two-wire load resistance, see the figure below:

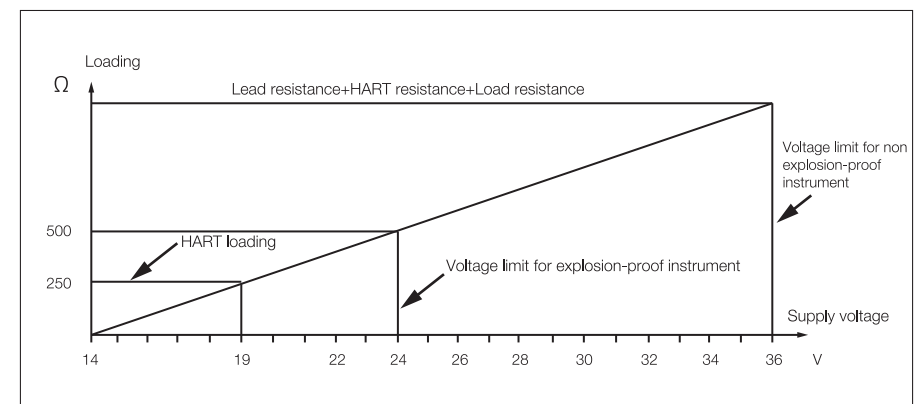

5 WIRING INSTRUCTION

5.1 Wiring Method

5.1.1 Two wire system 4...20mA/HART

(1) Single chamber two-wire housing(24V)

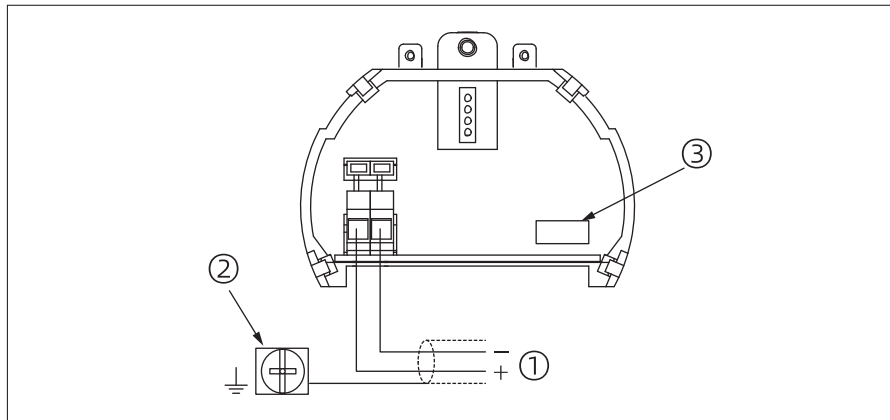

①24V Power cord ②Grounding screw inside the housing ③LCD connection module

(2) Dual chamber two-wire housing(24V)

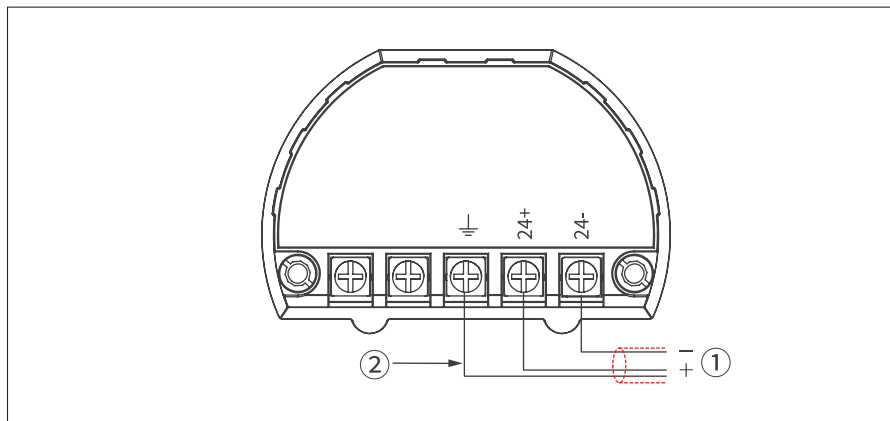

①24V Power cord ②Grounding screw inside the housing

(3) Dual chamber two output housing(24V)

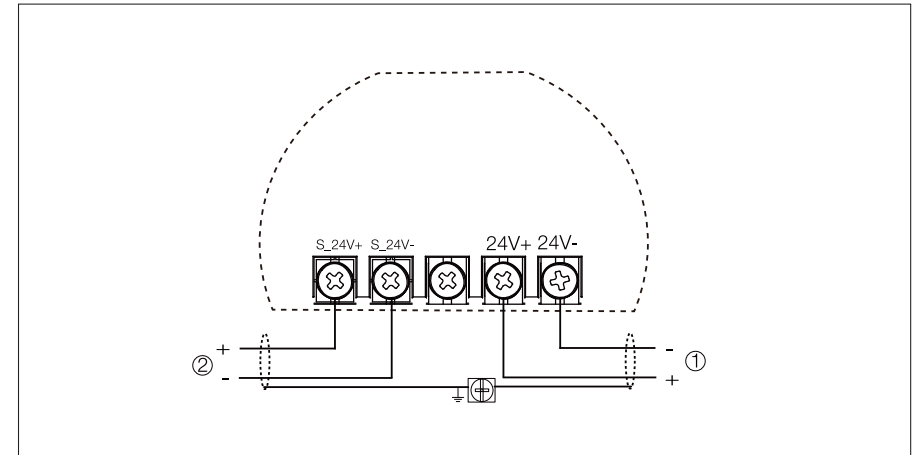

①Dual output radar main supply circuit (liquid level), 24V power supply
②Dual output radar second output (interface) power supply circuit, 24V power supply

5.1.2 Four-wire system 4...20mA/HART

(1) Dual chamber four-wire housing(24V)

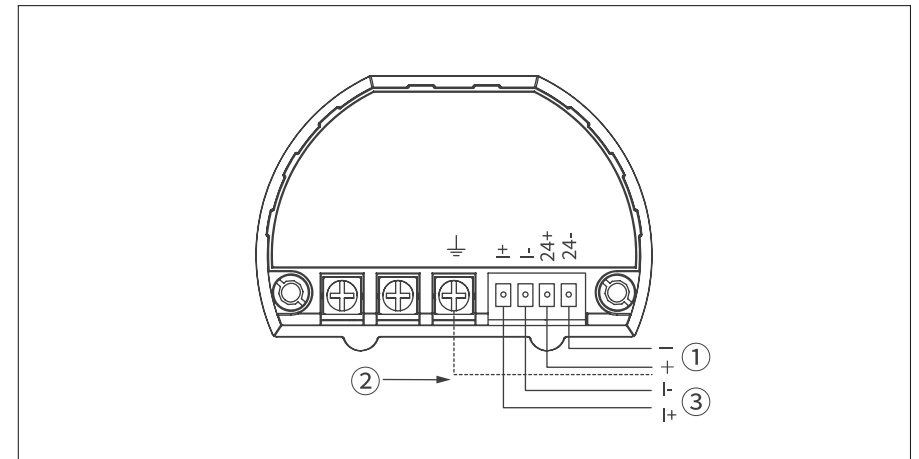

①Current signal wire ②Grounding screw inside the housing ③24V power cord

(2)Dual chamber four-wire housing(220V)

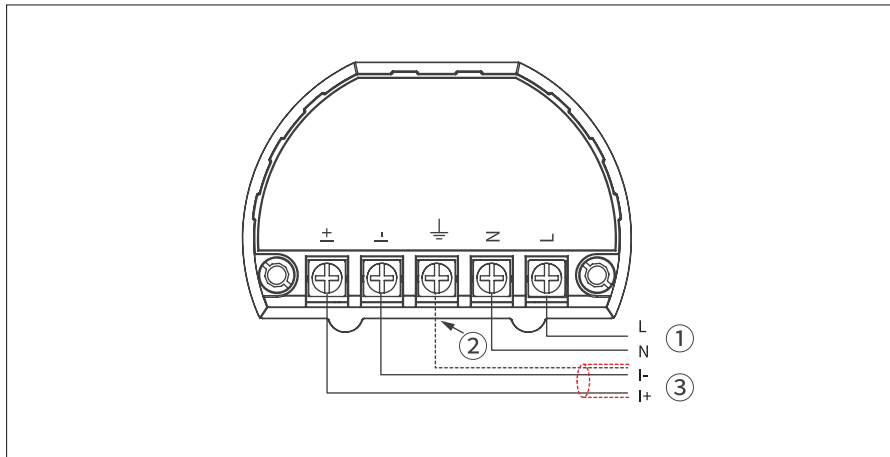

①220V Power cord ②Grounding screw inside the housing ③Current signal wire

Note: If the current signal is not connected to the central control room on site, it is necessary to short circuit I+and I- with wires!

5.1.3 Modbus

(1)Modbus wiring diagram

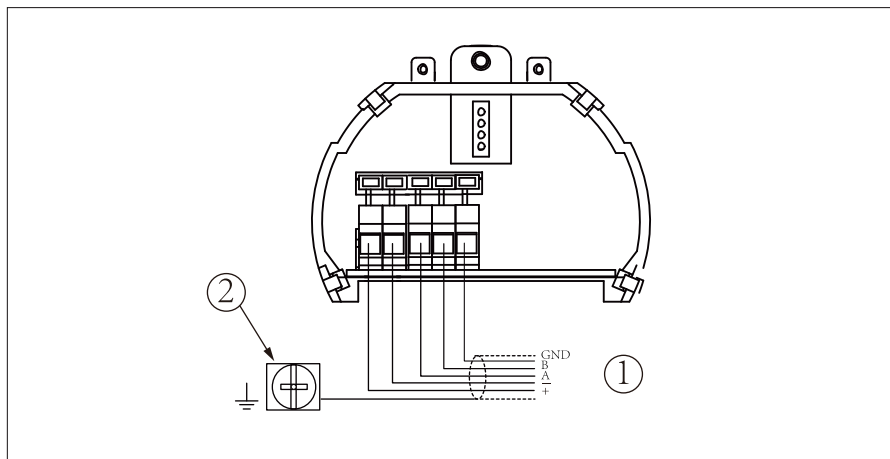

①24V power cord ②Grounding screw inside the housing

5.1.4 Remote display unit

(1)24V Single chamber two-wire passive tank side wiring diagram

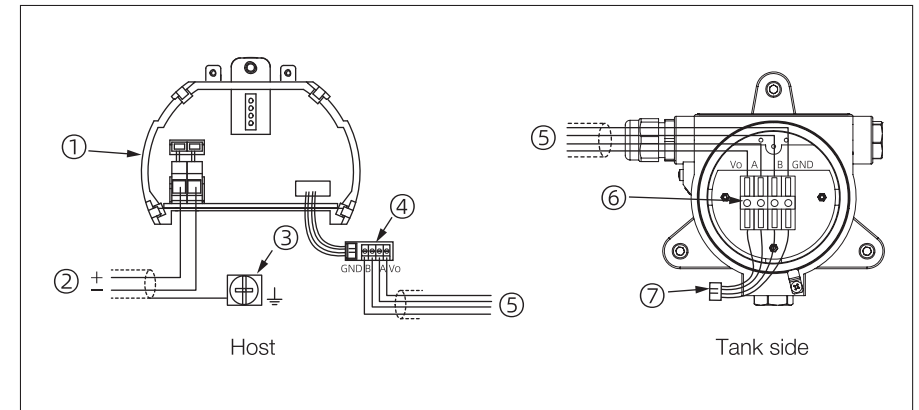

①Radar electronic unit ②24V power cord ③Grounding screw inside the meter housing
④485 signal wiring terminal ⑤Tank side signal wire (4-core) ⑥Tank side wiring terminal
⑦LCD line (connected to LCD)

(2)24V Single chamber two-wire positive tank side wiring diagram

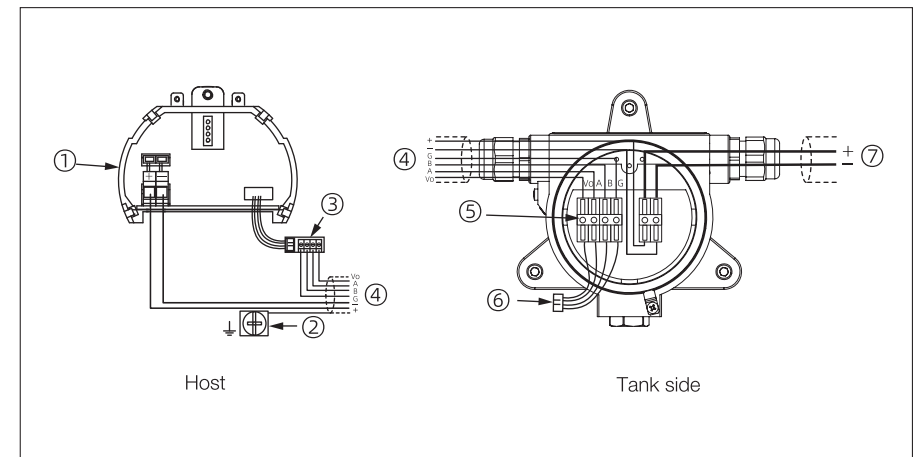

①Radar electronic unit ②Grounding screw inside the housing ③485 signal wiring terminal
④Tank side power/signal connection wire (6-core) ⑤Tank side wiring terminal
⑥LCD line (connected to LCD) ⑦24V power cord

(3) 24V Dual chamber two-wire passive tank side wiring diagram

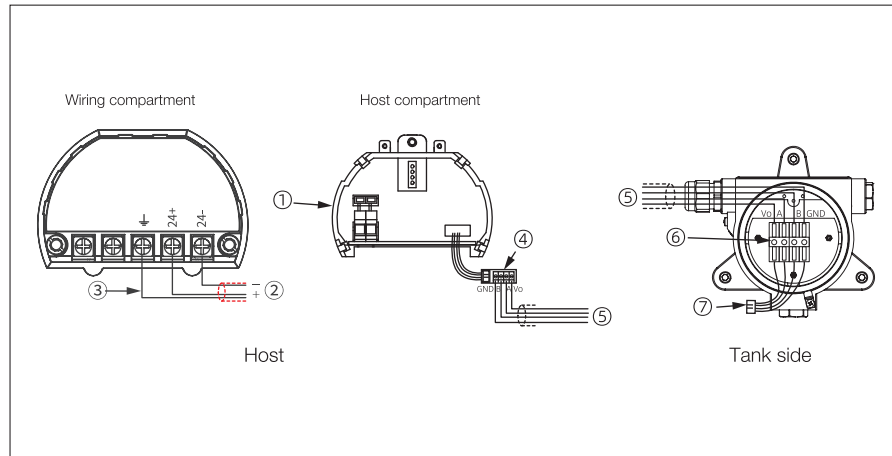

- ① Radar electronic unit
- ② 24V power cord
- ③ Grounding screw inside the meter housing
- ④ 485 signal wiring terminal
- ⑤ Tank side signal wire (4-core)
- ⑥ Tank side wiring terminal
- ⑦ LCD line (connected to LCD)

(5) 220V Dual chamber four-wire passive tank side wiring diagram

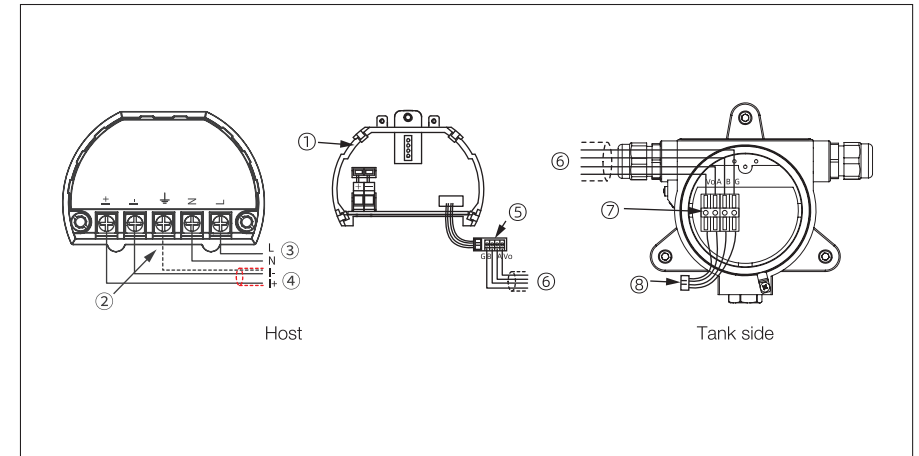

- ① Current signal wire
- ② Grounding screw inside the meter housing
- ③ 220V power cord
- ④ Radar electronic unit
- ⑤ 485 signal wiring terminal
- ⑥ Tank side signal line (4-core)
- ⑦ Tank side wiring terminal
- ⑧ LCD line (connected to LCD)

(4) 24V Dual chamber four-wire passive tank side wiring diagram

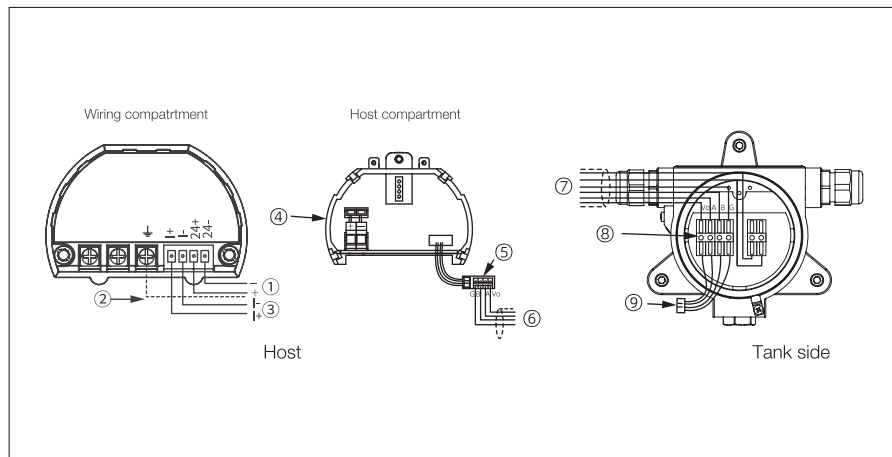

- ① 24V power cord
- ② Grounding screw inside the meter housing
- ③ Current signal wire
- ④ Radar electronic unit
- ⑤ 485 signal wiring terminal
- ⑥ Tank side signal wire (4-core)
- ⑦ Tank side signal wire (6-core)
- ⑧ Tank side wiring terminal
- ⑨ LCD line (connected to LCD)

6 INSTRUMENT DEBUGGING TYPE

There are four debugging methods for guided wave radar level meter:

- a) Instrument LCD display unit
- b) Remote LCD display unit for instruments (tank side display unit)
- c) Upper computer debugging software
- d) Radar specific HART communicator (capable of all operations) or ROSEMOUNT375/475 (limited to HART general instructions)

6.1 Instrument LCD Display Unit

The instrument LCD display unit is an on-site display debugging tool that can be rotated onto the top of the instrument electronic unit. The LCD with a 128 * 64 graphic lattice can facilitate the observation of the echo curve. The instrument can be debugged through the four keys on the instrument LCD unit. The language of the debugging menu is optional. After completing the setup, the LCD unit is generally only used for display, and the measured values can be read very clearly through the glass window, convenient on-site inspection.

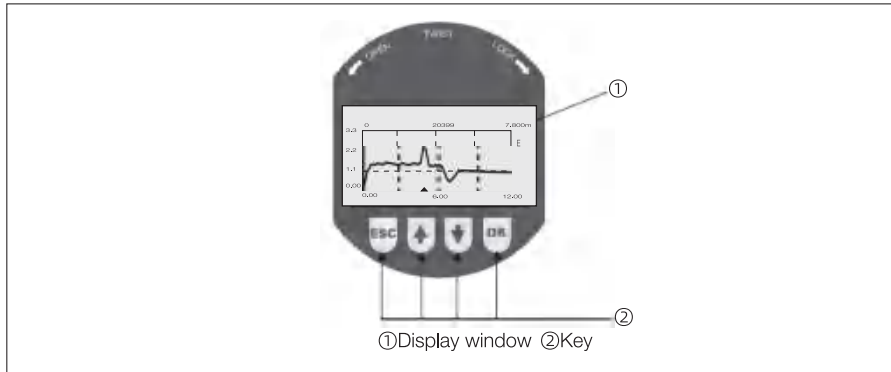

[ESC] key: Exit this level of menu; Exit editing status; Switching between waveform interface and main interface

[OK] key: Enter parameter editing status; Confirm parameter saved; Entering the lower level menu while browsing the menu

[↓] key: Loop down through menu items; Select the specific location for editing parameter; Cursor movement on the right side of the waveform amplification interface

[↑] key: Loop up (select) menu items; Cycle to change values; Cursor movement on the left side of the waveform amplification interface

6.2 Instrument Remote LCD Display Unit (tank side display unit)

The instrument LCD display unit of the guided wave radar level meter can be connected to the remote end for display through a shielded 4-core cable with an external connection of 25 meters. By utilizing this feature, it is convenient to form remote display units or tank side display units on site. Reduce the workload of instrument maintenance. Reduce the workload of climbing tanks. For some hazardous instrument installation environments, this remote LCD display unit can better protect the safety of on-site maintenance personnel.

(1) Remote display unit - active tank side

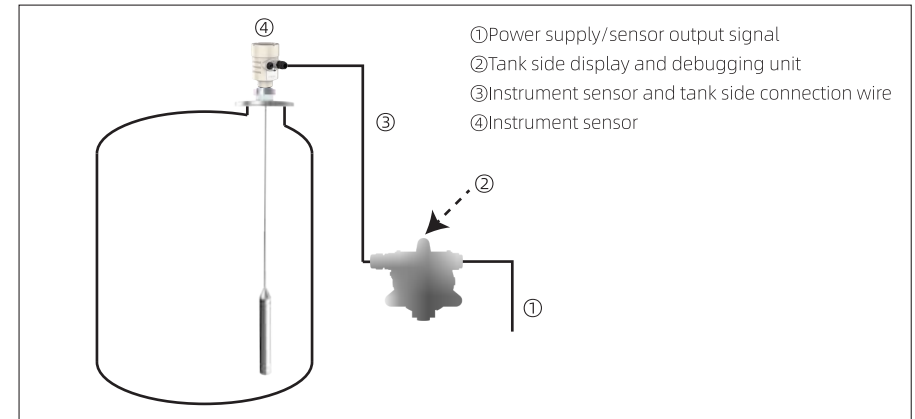

(2) Remote display unit - passive tank side

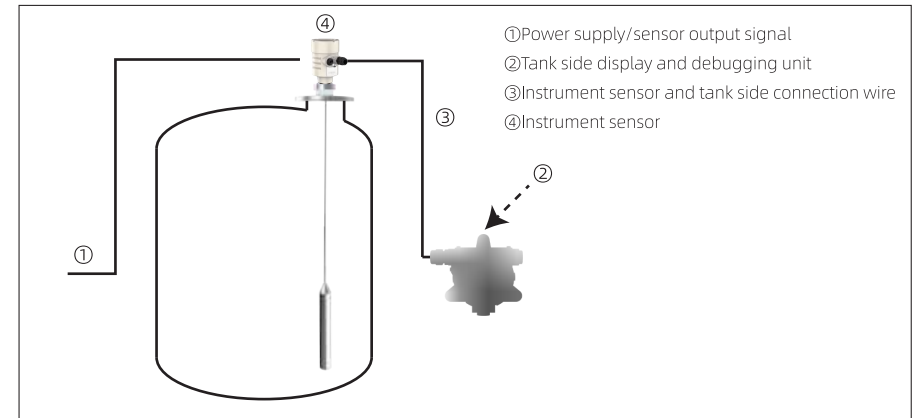

6.3 Upper Computer Debugging Software

Debugging through the Radarmaster software, connecting the instrument to the computer USB interface through RS485 communication interface

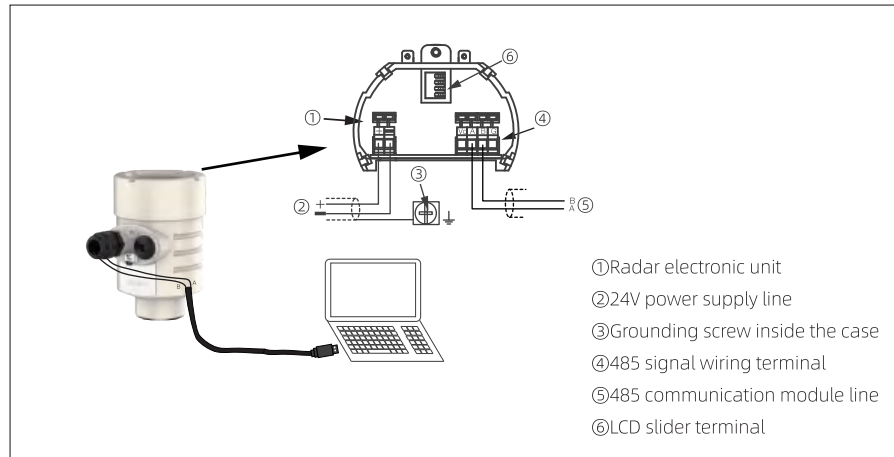

②Guided wave radar level meter

③HART of 250 ohms resistance (if the DCS in the central control room already has an internal resistance of 250 ohms, this resistance can be omitted, and the HART handheld programmer can be directly connected to both ends of the control cabinet wiring terminals) powered by an external power supply or battery. The HART handheld programmer can form an LCD display unit in the central control room for long-term observation of the instrument's working status.

6.4 HART Communicator(LCD display unit in central control room)

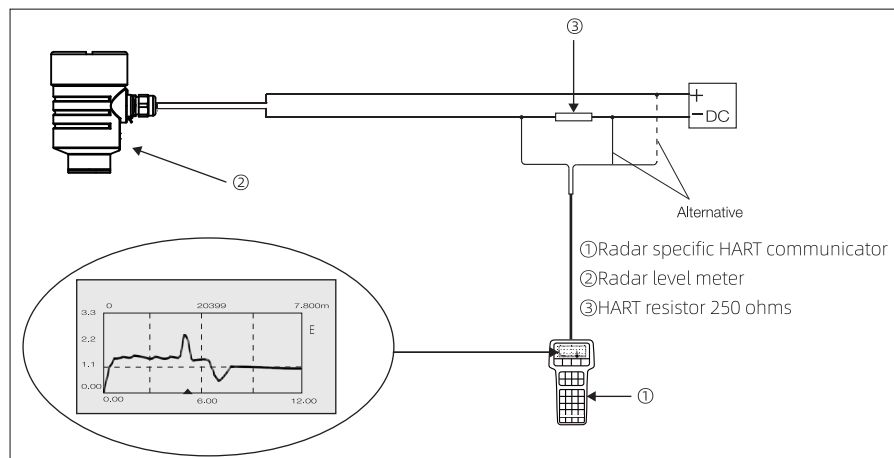

① The specialized HART communicator for radar level meter

7 INSTRUMENT DISPLAY UNIT PARAMETER SETUP

7.1 Menu Structure Diagram

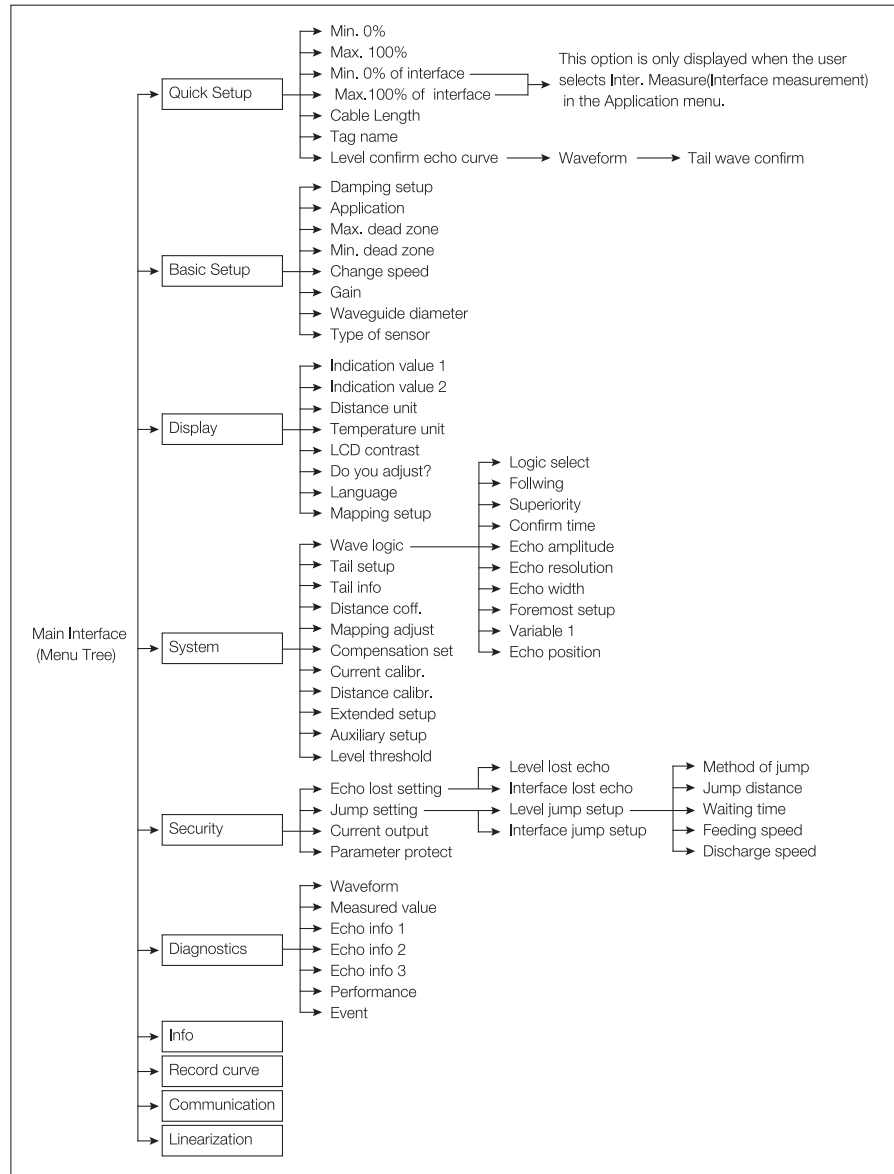

7.2 Basic Setting Method

7.2.1 Programming Method

When the instrument is in the main interface display state, press the [OK] key to enter the main menu.

Press the [↓] key to scroll down or the [↑] key to scroll up through the menu, then press the [OK] key to enter a submenu. Once in the parameter editing interface, press the [OK] key to enter editing mode. Each parameter must be confirmed with the [OK] key after editing; otherwise, the modification will be invalid. After completing the edits, press the [ESC] key to exit programming mode and return to the previous menu.

7.2.2 Parameter editing method

Numerical/Character Parameter Programming: When entering a menu that requires numerical or character input, the first digit of the parameter will be highlighted. Press the [↑] key to change the highlighted digit or character until the desired value is displayed. If the highlighted position is a decimal point ("."), pressing the [↑] key will move it one position to the right. Press the [↓] key to shift the highlighted position to the right, allowing selection of different digit positions for editing.

Selectable Parameter Programming: Selectable parameters refer to options where multiple preset values are available for user selection. Use the [↓] or [↑] key to navigate through the available options, then press the [OK] key to confirm the selection.

Note: In the parameter editing interface, the [↑] key is used to change the value of the selected digit, including numbers 0-9 and the decimal point. If the selected digit is the first character of a number, a negative sign can also be selected. Pressing the [↑] key at a decimal point will shift it one position to the right. If the decimal point is already at the last position (e.g., "8888."), pressing the [↑] key again will move the decimal point to the second position, changing the value to "0.8888".

7.3 Main Interface Introduction

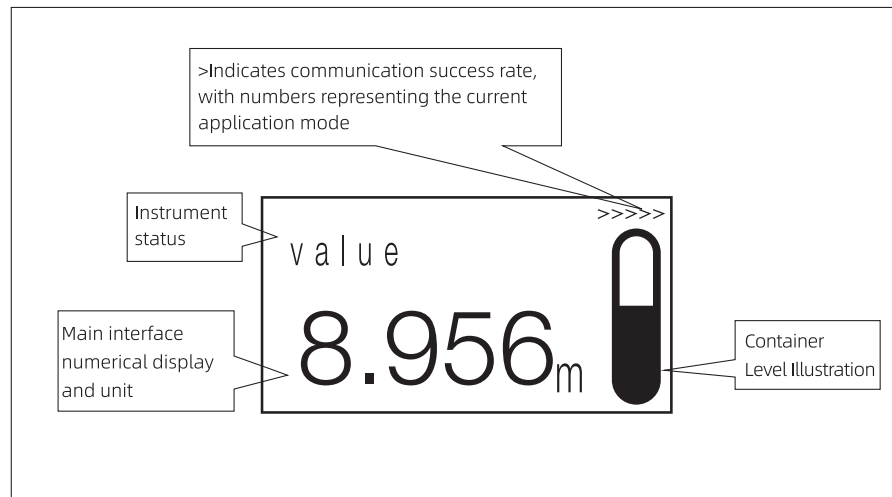

Instrument status: 1.Fault, 2.High Level Alarm, 3.Low Level Alarm, etc. If there is no display at this position, it indicates that the instrument is working normally.

The graphic display of the container's material level is represented by a cylindrical shape, with the black part representing how much material has been added to the container and the white part representing how much space is left in the container.

The unit displayed on the main interface represents the value and unit displayed on the main interface.

The upper right corner of the main interface displays numbers to quickly view which application mode it is.

The upper right corner represents the successful communication rate between the LCD and electronic unit in the past 20 times, represented by 5>. The display of 5> indicates 100% successful communication, and the display of 0> indicates 0% successful communication.

7.4 Echo Quick View Interface

Press the [ESC] key on the main screen to enter the echo shortcut viewing interface, as shown in the following figure. Press the [ESC] key again on the echo quick view interface to return to the main interface.

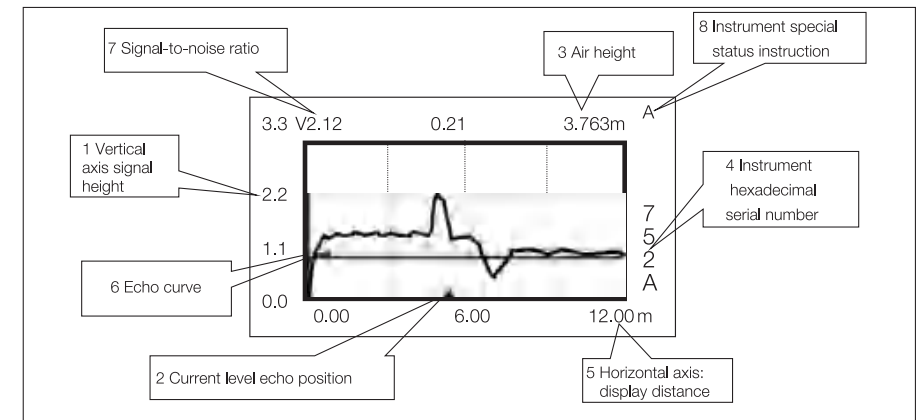

1.The vertical axis in the waveform represents the signal strength. The unit is V. The vertical axis is divided into three equal parts by a horizontal dashed line, namely 1.1V, 2.2V, and 3.3V, to distinguish the height of the signal waveform.

2.The triangle represents the current echo that the instrument considers to be the echo of the material surface. Display the altitude represented by the echo indicated by the triangle. The distance from this echo to the instrument.

3.Air height refers to the distance from the upper surface of the instrument flange (corresponding to the upper end of the connecting thread for instruments without flanges) to the material surface.

4.Vertical four-digit number/letters represent the hexadecimal serial number of the table.

5.The horizontal axis in the waveform represents the distance. The leftmost 0 point represents the instrument panel. From left to right represents the direction away from the instrument panel. Usually, 0 represents the top of the container, and from left to right represents top to bottom. The value on the far right of the horizontal axis defaults to the low range plus 2 meters.

6.The solid lines in the waveform represent the echo curve. The peaks in the curve represent echoes. Echoes may be generated by the reflection of the material surface, and we call them true echoes. It can also be generated by the adhesive on the antenna, pipes on the container wall, ladders, feeding ports, and other objects inside the container, which we call interference waves.

7.The signal-to-noise ratio of the front wave represents the energy of the echo, and usually the stronger the energy, the more likely the echo is to be generated by the real material surface.

8.Display method: Display a letter after the distance value in the upper right corner of the curve interface, with different letters corresponding to different working states.

Letter identification	Status
A	Normal Measurement Mode
B	Waiting for Level Confirmation
C	Jump Detection Confirmation
D	Waiting for Transition
E	Overflow Alarm
F	Low-Level Alarm
G	Loss of Echo Handling – Hold Last Value
H	Loss of Echo Handling – Set to Specified Value
I	Loss of Echo Handling – Output Empty
J	Loss of Echo Handling – Output Full
K	Loss of Echo Handling – Trend Tracking
L	Loss of Echo Handling – Alarm Output
M	Loss of Echo Handling – Output to Interface
N	Tail Echo Suppression – Force Empty Indication
O	Tail Echo Suppression – Auxiliary Empty Indication
P	Tail Echo Suppression – Auxiliary Full Indication
Q	Tail Echo Suppression – Auxiliary Empty/Full Indication

7.5 [Quick Setup] Menu

For simple on-site conditions, just complete the quick setup and the instrument can be used.

Quick setup mainly includes range setting and confirmation of current material level. In the main interface display state, press the "OK" key to enter the menu browsing state, and the LCD display is shown in the following figure.

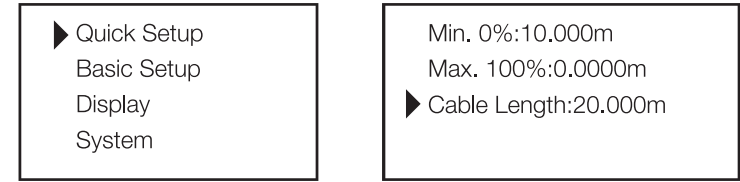

Note: The number on the right is the menu number

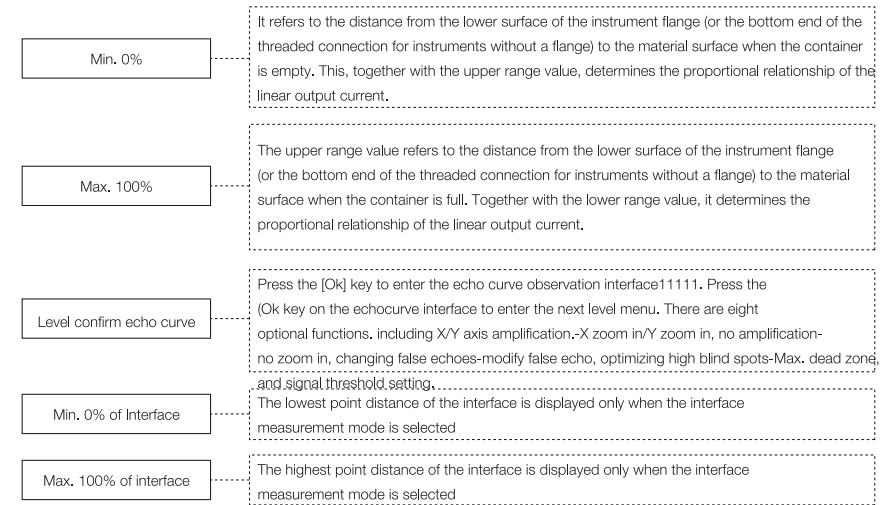

Explanation of information under different application modes when viewing waveforms through "level confirm echo curve".

Interface measurement mode:

- 1.The upper line displays the interface distance, control frequency, and material level distance.
- 2.The low and high amplitude limit horizontal dashed lines will be displayed, and the threshold set horizontal solid line will be displayed, which is the amplitude threshold of the interface.
- 3.Display vertical dashed lines for high and low blind spots.
- 4.It will display the tail echo position, as well as the left and right limits of the tail echo position.

5.The triangle indicator symbol represents the position of the material level, and the square indicator symbol represents the position of the interface.

6.The curve shows the end point of the horizontal axis=the maximum value of the low range and cable length * the square root of the top layer dielectric constant+0.5.

High temperature and high-pressure measurement:

1.The upper line displays the reference echo distance, control frequency, and material level distance.

2.The low limit and high limit horizontal dashed lines will be displayed, and the threshold set horizontal solid line will be displayed, which is the amplitude threshold of the material level.

3.Display vertical dashed lines for high and low blind spots.

4.It will display the tail echo position, as well as the left and right limits of the tail echo position.

5.The triangle indicator symbol represents the material level position, the R indicator symbol represents the first reference echo position, the S indicator symbol represents the second reference echo position, and the T indicator symbol represents the third reference echo position.

6.The curve shows the end point of the horizontal axis=the maximum value of the low range and cable length+0.5.

Other application measurements:

1.The upper line displays the echo amplitude, echo width, and material level distance.

2.The low limit and high limit horizontal dashed lines will be displayed.

3.Display vertical dashed lines for high and low blind spots.

4. It will display the tail echo position, as well as the left and right limits of the tail echo position.

5.The triangular indicator symbol represents the position of the material level.

6.The curve shows the end point of the horizontal axis=the maximum value of the low range and cable length+0.5.

Note 1: The echo curve is shown in the following figure.

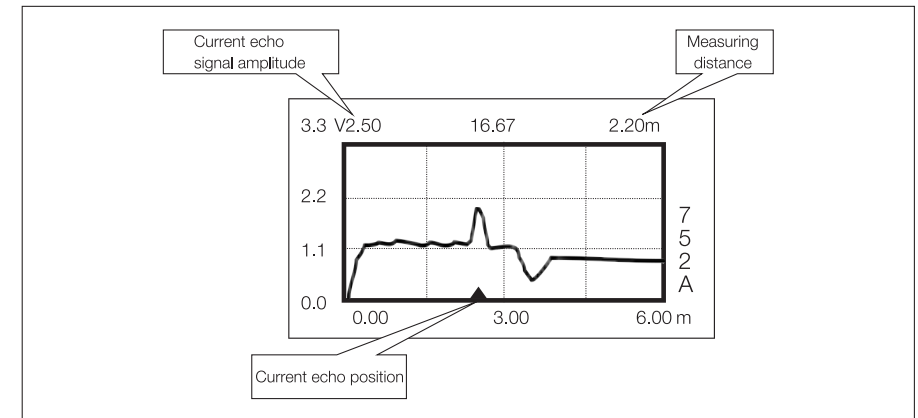

Note 2: X/Y axis magnification

On the echo curve observation interface, press the [OK] key to enter the curve operation selection screen, which includes: X-axis amplification-X zoom in (distance axis amplification), Y-axis amplification-y zoom in (amplitude axis amplification), no amplification-No zoom in, changing false echoes-modify false echo, optimizing high blind spot-Max. dead zone, optimizing low blind spot-Min. dead zone, and signal threshold setting. At this point, you can use the [↓] and [↑] keys to select the function you want to operate. After clicking the [OK] key, the waveform will appear, and a straight line will appear near the Y-axis (X-axis amplification) or X-axis (Y-axis amplification) in the waveform coordinate system. You can use the [↓] or [↑] keys to move this straight line. At the same time, the upper right corner of the coordinate system displays the current meter or amplitude of the position. After moving to the corresponding position, press the [OK] key, A second line will appear immediately next to the first line, then move the second line to the desired position and press the [OK] key to enlarge the local waveform. If you do not need to amplify the waveform, select "No zoom in" and the waveform will return to its original position.

7.6 [Basic Setup] Menu

Damping setup	Damping (0-99), default 5
	<p>Second damping (interface damping/reference damping) (0-99), default is 5.</p> <p>This item is only displayed when selecting interface measurement for the application, which is interface damping for interface measurement.</p> <p>The item will only be displayed when selecting high-temperature and high-pressure measurement for the application, which is the reference damping for high-temperature and high-pressure measurement.</p> <p>There is a maximum of 3 reference points, which share a damping time when calculating distance (this damping time is the second damping).</p>
Application	Optional medium type, dielectric constant, application, upper liquid dielectric constant (This option is only displayed when the user selects Inter. Measure in the Application menu, default is 1)
Max. dead zone	(-30~Min. dead zone -0.1), default is 0. Electronic unit end is -30~69.9. Set according to the on-site environment and instrument type.
Min. dead zone	(Max. dead zone+0.1~70), default is 20. Electronic unit end is -29.9~70. Set according to on-site environment and instrument type.
Change speed	(0.1~70) default is 0.4, which is set based on the on-site material level change speed.
Gain	Parameter used to set waveform height, default to three levels

7.7 [Display] Menu

Indication value1	<p>Distance, level height, empty height, current, percent, temperature, mapping1</p> <p>Display items only when the application is selected as 'Interface Measurement'</p> <p>Interface distance</p> <p>Interface level height</p> <p>Interface empty height</p> <p>Upper layer thickness</p> <p>Interface current</p> <p>Interface percent</p> <p>Upper layer DC</p> <p>Mappint 2</p>
Indication value2	Same as 'Indication value1'
Distance unit	Meters, Decimeter, Centimeter, Millimeter, ft
Temperature unit	°C °F K
LCD Contrast	Adjust the contrast through [↓] and [↑]. When the adjustment is appropriate, press [OK] to save, and press [ESC] to discard the modification
Language	Chinese(defaultly), English, Spanish optional
Mapping 1 setup	Mapping: Yes/No, default is no, 0~1, 1 represents off mapping display, 0 represents on mapping display, default is 1.
Mapping 2 setup	Mapping: Yes/No, default is no, 0~1, 1 represents off mapping display, 0 represents on mapping display, default is 1.

7.8 [System] Menu

Wave logic	Used to set logic select, following, superiority, confirm time, echo amplitude, echo resolution, echo width, foremost setup, variable1, echo position.
Tail setup	Used to set tail control, judgment method, and bottom setting.
Tail Information	Used to display information such as tail wave position, voltage, resolution, front and rear edge distance, etc.
Distance coefficient	Used to set zero scale parameters, including level coefficient and interface coefficient (this setting item will only be displayed when the application selects interface measurement).
Mapping adjust	Max. mapping and min. mapping.
Compensation set	Used to set distance compensation, normal calibration, and safety distance. Currently, the compensation set is only valid for high-temperature and high-pressure applications.
Current calibration	Used to set forced current damping, level current, and interface current (when the material level is reached, 1 will be displayed in the upper right corner, and 2 will be displayed in the upper right corner of the interface)
Distance calibration	Used to set level distance and interface distance (when the material level is reached, 1 will be displayed in the upper right corner, and 2 will be displayed in the upper right corner of the interface).
Extended setup	Used to set variable group.
Level threshold	Used to set high distance threshold/amplitude, low distance/amplitude.

Note 1: The forced current refers to the current input by the instrument output user (the forced current value is 3.5-23mA).

Note 2: Zero point correction is used to set the distance when the actual distance measured by the instrument is zero.

7.9 [Security] Menu

Echo lost setting	Level lost echo and Interface lost echo are optional.
Jump setting	Level jump setup and interface jump setup are optional.
Current output	Current direction, alarm output, boot current, max. current, min. current are optional.
Parameter protect	Login, exit login, write protect, password set, restore factory parameter, restore default parameter, save factory parameter are optional.

Note 1: [Echo lost setting]

The echo lost setting can choose hold, assign, trend, alarm, and other instructions.

Hold: When no echo is detected, the instrument displays the preset distance.

Assign: When no echo is detected, the instrument retains the last measured distance.

Trend: When no echo is detected, the instrument output follows the previous trend.

Alarm: When no echo is detected, the instrument outputs an alarm current and displays a "No Echo" warning.

[Interface Lost Echo] settings are the same as [Echo Lost Setting] settings and are only visible when the user selects interface measurement in the Application menu.

Note 2: [Method of jump]

The echo lost setting can choose instructions such as direct jump, delay jump, trend jump, and with speed jump.

Direct jump: When the material fluctuation exceeds the set change distance, the distance displayed on the instrument directly displays the current distance.

Delay jump: When the material fluctuation exceeds the set distance, the instrument will wait for the set waiting time before displaying the current distance.

Trend jump: When the material fluctuation exceeds the set change distance, the instrument slowly keeps up with the current displayed distance based on the material speed in the previous period.

With speed jump: When the material fluctuation exceeds the set change distance, the instrument will follow the set jump speed and slowly keep up with the current displayed distance. The settings for [Interface Jump Setup] is same as those for [Level Jump Setup]. This setting item will only be displayed when the application selects interface measurement.

Note 3: [Current direction]

4-20mA and 20-4mA are optional.

4-20mA indicates that the low material level corresponds to 4mA, and the high material level corresponds to 20mA.

20-4mA indicates that the low material level corresponds to 20mA, and the high material level corresponds to 4mA.

Note 4: [Alarm output]

Unchanged, 3.5mA, 20mA, and 22.5mA options, used to specify the current output during alarm.

Note 5: [Boot current]

Unchanged, 3.5mA, 20mA, and 22.5mA options, used to specify the current output when the instrument starts.

Note 6: [Parameter protect]

Password set: Used to protect menu items. After setting the password, a password must be entered to enter the menu, which can prevent others from modifying instrument parameters.

Write to instrument: Used to write the parameters of the instrument into the LCD, which is generally not used by users.

Restore factory parameter: Restore the parameters of the instrument to the factory settings.

Save factory parameter: Save the parameters set at the factory.

Restore default parameter: Restore the instrument to its original parameters.

Waveform	Used to view waveform information and enter the waveform menu interface.
Measured value	Used to display the maximum and minimum values of trigger echoes, as well as the maximum and minimum values of material level echoes. The maximum and minimum values of the reference echo are only displayed when the application selection is set to 'Application 7' (high temperature and high pressure). The maximum and minimum values of the interface echo are only displayed when the application selection is set to 'Application 6' (interface measurement). Press the OK key, and the maximum and minimum values will be recorded and cleared to zero.
Echo Info 1	Five echo informations, sorted by weighted amplitude or resolution from highest to lowest. Echo distance, echo amplitude, echo resolution, echo weight, echo property.
Echo Info 2	By pressing the up and down keys to switch between echo numbers, a total of 10 echo informations can be viewed.
Echo Info 3	Used to view trigger echo information, level echo information, first reference information, second reference information, third reference information, compensated distance.
Performance	Used to view performance parameter change records.
Event	Used to view records of changes in events.

7.11 [Information] Menu

Used to display information such as date of manufacture, serial number, instrument type, software version, etc.

7.12 [Record Curve]

Echo curve	Used to record instrument jump echo, full echo and other informations.
Historical curve	Used to display record interval, record data, recording method, display method, delete record, display curve, etc.

7.13 [Communication]

Used to configure HART communication settings, including communication address(Address), communication mode(method), and variables.
Used to configure Modbus communication settings, including communication address(Address), baud rate(BaudR), data bits(DataB), stop bits(StopB), parity, protocol, and communication functions.

7.14 [Linearization]

Functions for configuring linearization, including distance linearization(Dist linearization), distance editing(Dist lin edit), ratio linearization(Percent linearization), and ratio editing (Percent lin edit).

8 CONFIRMATION OF DEBUGGING ACCEPTANCE

1. Confirm that the instrument is properly grounded;
2. Confirm that the instrument measurement is normal and the output is consistent with the settings in the central control room;
3. Confirm that the outlet of the instrument cable has been tightened and sealed, the outlet of the cable has been blocked and installed reliably, and ensure that the instrument conduit arranged on site does not cause water accumulation in the instrument;
4. Confirm that the instrument housing cover has been tightened.

Common Fault Handling

No.	Fault phenomenon	Cause analysis	Elimination method
1	The display in the central control room is normal, but there is no display on the instrument panel.	Poor connection of LCD display unit.	Open the instrument housing cover and tighten the LCD display unit again.
		LCD display unit damaged.	Replace the LCD display unit.
2	The display in central control room is 0, but the instrument panel does not display it.	Poor power wiring.	Reconnect the power cord and firmly pull everything to ensure the connection is secure.
		The power wiring is reversed.	Change the polarity of the power cord and reconnect it.
		Instrument electronic unit damaged.	Replace the instrument electronic unit.
3	No echo(No signal)	The material surface is too high and enters the blind spot for high level measurement.	If obvious material echoes can be seen at this time, the high blind spot setting can be appropriately reduced. If no obvious material echo is visible, consider raising the position of the instrument or limiting the on-site feeding height. Alternatively, combined with the loss of wave setting, force the instrument to output at this time.
		The sensor cannot emit a signal due to material adhesion.	Clean the cable or probe rod.

Common Substances Dielectric Constant

Material	Dielectric Constant	Material	Dielectric constant	Material	Dielectric constant
Polystyrene	1.05~1.5	Dry coal dust	2.2	Wet sand	15~20
Laundry detergent	1.1~1.3	Gypsum	1.8~2.5	Plastic pellets	1.5~2
Grains	2.5~30	Glass	1.2~2.2	Dry sand	3~4
Coal ash	25~30	Ore	25~30	Asphalt	4~5
ABS granules	1.5~2.5	Flour	2.5~3.0	Fly ash	1.5~1.7
PVC powder	1.4	Raw glass	2.0~2.5	Sand	3~5
Aluminum powder	1.6~1.8	Calcium carbonate	1.8~2.0	Calcium chloride	11.8
Calcium sulfate	5.6	Aluminum sulfate	6	Coke	1.1~2.2
Coal dust	1.2~1.8	Rice	3~8	Nylon	4~5
Calcium sulfite	5	Soap powder	1.2~1.5	Starch	2~5
Ballmill feed cement	1.5~2.1	Grains	3~8	Asphalt	2.5~3.2
Sugar	1.5~2.2	Iron oxide	14.2	Corn residue	2.3~2.6
PE	1.5	Acrylic resin	2.7~6.0	Raw rubber	2.1~2.7
Wheat flour	2.2~2.6	PP	1.5~1.8	Cement	4~6
Ammonia	21	Latex	24	Potassium chloride	4.6
Gasoline	1.9	Isocyanate	7.5	Water	48~80
Cyclohexanol	2	Liquid petroleum gas	1.2~1.7	Edible oil	2~4
Diesel	2.1	Industrial alcohol	16~31	Acetone	20~30
Ethanol	2.5	Ether	5	Methanol	30
Acetone	19.5~20	Benzene (liquid)	2.3	Glycerol	37
Hydrochloric acid	4~12	Butanol	11	Sulfuric acid	84
Liquid nitrogen	1.4	Epoxy resin	2.5~6.0	Toluene (liquid)	2.0~2.4
Kerosene	2.8	Heavy oil	2.6~30	Urine	6.5~7.1
Paint	5~8	Liquid ethane	5.8~6.3	Vegetable oil	2.5~3.5
Dry wood	2.0~2.6	Carbon black	2.5~3.0	Methane	37.5
Wet wood	10~30	Carbon	5.8~7.0	Magnesium oxide	9.7
Quartz glass	3.8	Bleaching powder	4.5	Petroleum	2.0~2.2
Glass	3.6	Gravel	7.4	Lactic acid	22

Material	Dielectric Constant	Material	Dielectric Constant	Material	Dielectric Constant
Sodium chloride	6.1	Phosphorite	7.4	Graphite	12~15
Sodium carbonate	5.3~8.4	Aniline	5.5~7.3	Formamide	84
Liquefied petroleumgas	1.6~1.8	Nitric acid	50	Formaldehyde	84
Acetaldehyde	21.8	Salt	3.0~15	Coal slag	2.7
Acetic acid	6.2	Quicklime	2.0~3.0	Clay	1.8~2.8
Rubber solution	2.7~2.9	Zinc ore	9.3	Trichloromethane	5.5