

Submersible Hydrostatic Level Transmitter

Operation Manuals



1. Brief introduction

The submersible hydrostatic level transmitter is based on the principle that the static pressure of the measured liquid is proportional to the height of the liquid. The pressure signal is converted into electrical signal by the pressure sensor, and then converted into standard current signal or digital signal after temperature compensation and linear calibration.

It adopts the high quality imported silicon piezoresistive sensor or ceramic sensor, with air conducting cable structure, reliable sealing technology, superior stability, modularized design, good applicability. Has analog and RS485 digital output. Could be widely used in the liquid level measuring situations of any industries.

2. Technical data

Measuring Range:

Min.0~0.5m Max.0~350m

Measuring Accuracy:

0.1%FS 0.2%FS 0.5%FS

Allowable Ambient Temperature:

-40°C~+85°C

Allowable Medium Temperature:

-20°C~+85°C

Allowable Storage Temperature:

-40°C~+85°C

Temperature Influence:

0.5% accuracy level -20 °C ~+80 °C every 10K \pm 0.15%, and every 10K \pm 0.2% in other temperature ranges;

0.2%, 0.1% accuracy level -20 °C~+80 °C per 10K \pm 0.1%, and other temperature ranges per 10K \pm 0.15%;

Power Supply:

Digital type: 12V DC~30V DC

Analog type: 7VDC~30VDC

Output:

(4~20) mA two-wire analog signal or RS485 communication MODBUS RTU communication protocol or special requirements agreed upon

Long Term Stability:

Accuracy levels of 0.5%, 0.2%, and 0.1% are better than 0.2% FS annually

Allowable Ambient Humidity:

95%HR

Transmitter Protection Grade:

Die cast aluminum epoxy coated shell IP66

ABS Connection Box IP65/IP67

Process Connection Standard:

External thread installation, flange installation, other installations

Other Electric Parameters:

Cable entry hole internal thread M20X1.5 or special requirements agreed upon

Display Analog 3 1/2 Digital Display

Response time: Analog 60ms, Digital 200ms

Electromagnetic compatibility:

The radiation immunity of radio frequency electromagnetic fields complies with GB/T17626.3-1998 10V/m and meets Class A standards

The conducted immunity of RF field induction complies with GB/T17626.6-1998, U=10V, and meets Class A standards

3. Dimensions

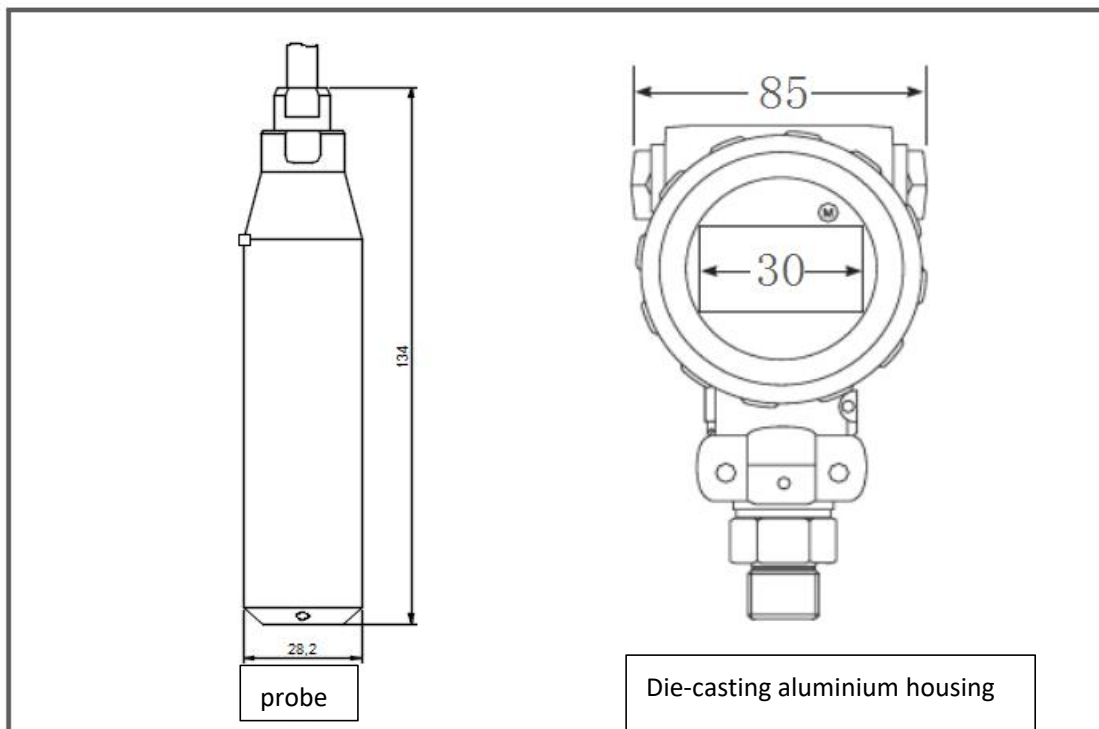

4. Load characteristics

The allowable load range can be calculated according to the following formula:

$$RL = (V_{sup} - V_{min}) / I - R_w$$

In the formula: R_L is the load resistance (Ω)

V_{sup} is the power supply voltage (V)

V_{min} is the min voltage (V)

I is the max output current (A)

R_w is the conductor resistance (Ω)

For example: power supply 24V DC, V_{min} is 7V DC, I is 0.02A, R_w is 30 Ω load resistance, so R_L max is $(24-7)/0.02-30=820 \Omega$.

5. Installation

Note: Die-casting aluminium housing can't be install upside down.

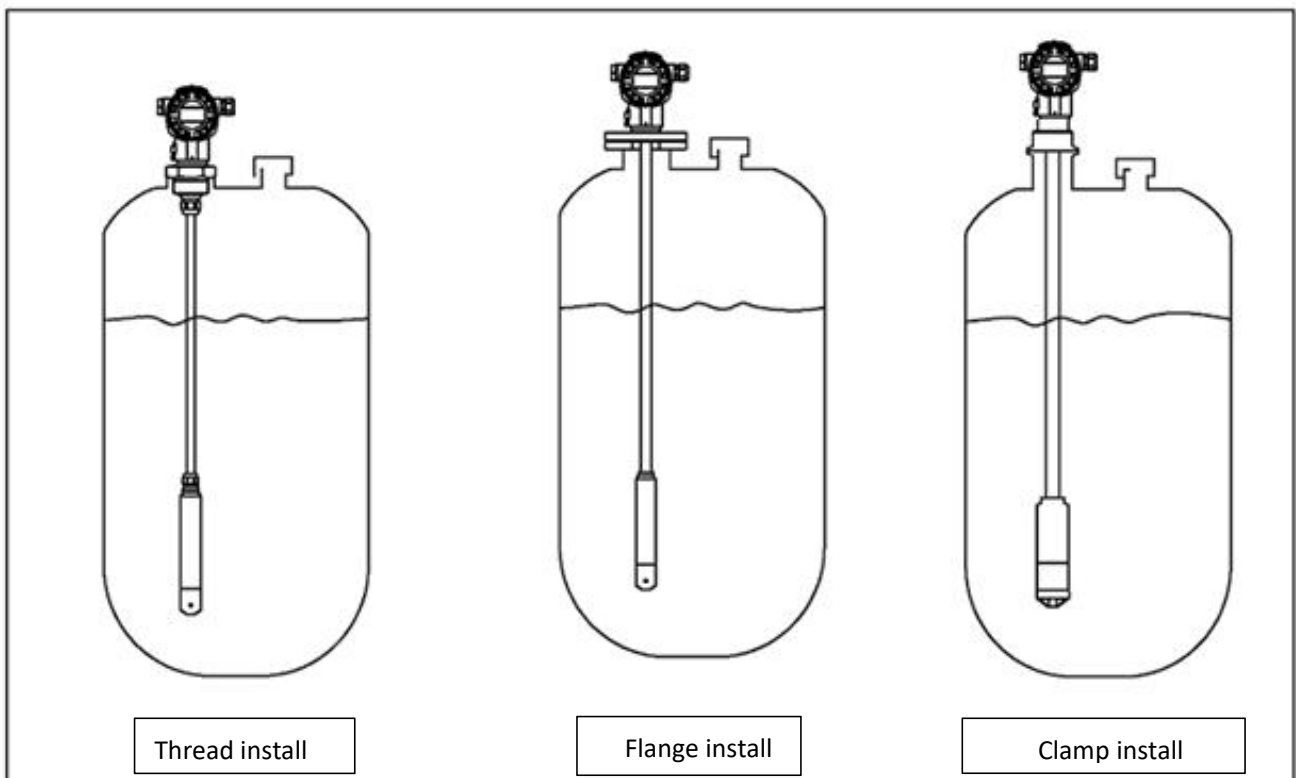

6. Wiring instructions:

6.1 With display header:

6.1.1 (4-20) mA output:

OUT + to 24VDC + ;

OUT - to 24VDC - ;

6.1.2 RS485 output:

OUT + to 24VDC + ;

OUT - to 24VDC - ;

TEST + to 485A;

TEST - to 485B;

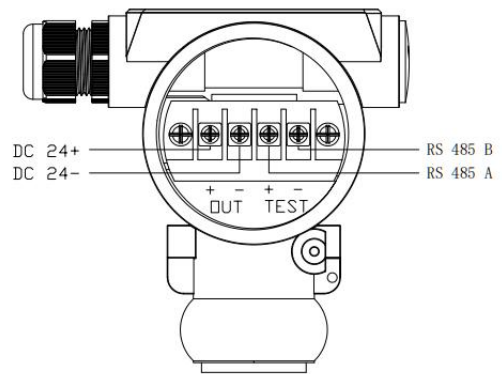
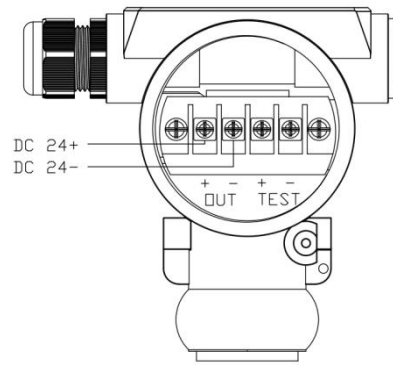

6.2 Without display header:

6.2.1 (4-20) mA output:

Red 24VDC + to 24VDC + ;

Black 24VDC - to 24VDC - ;

6.2.2 RS485 output:

Red 24VDC to 24VDC + ;

Black 24VDC - to 24VDC - ;

Brown RS 485A to 485A;

Blue RS485B to 485B;

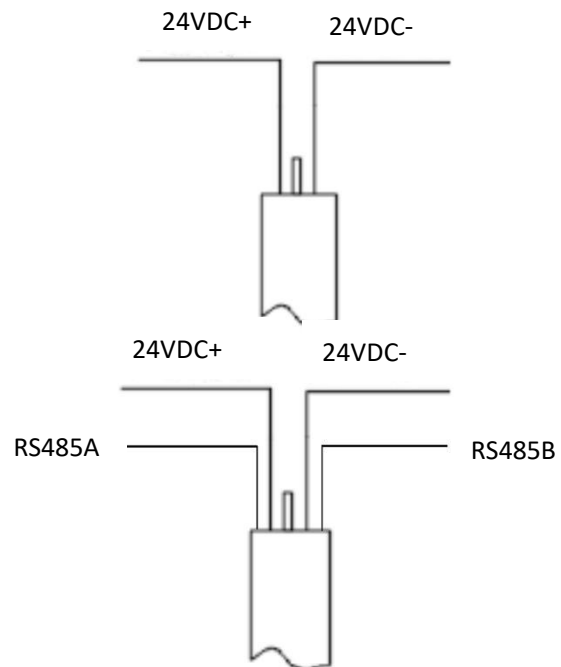

Note: In environments with strong interference, in order to ensure the normal operation of instruments, reliable grounding should be carried out according to relevant instrument grounding technical specifications!

7. Operation description (DB-50)

7.1 4-20mA output mode

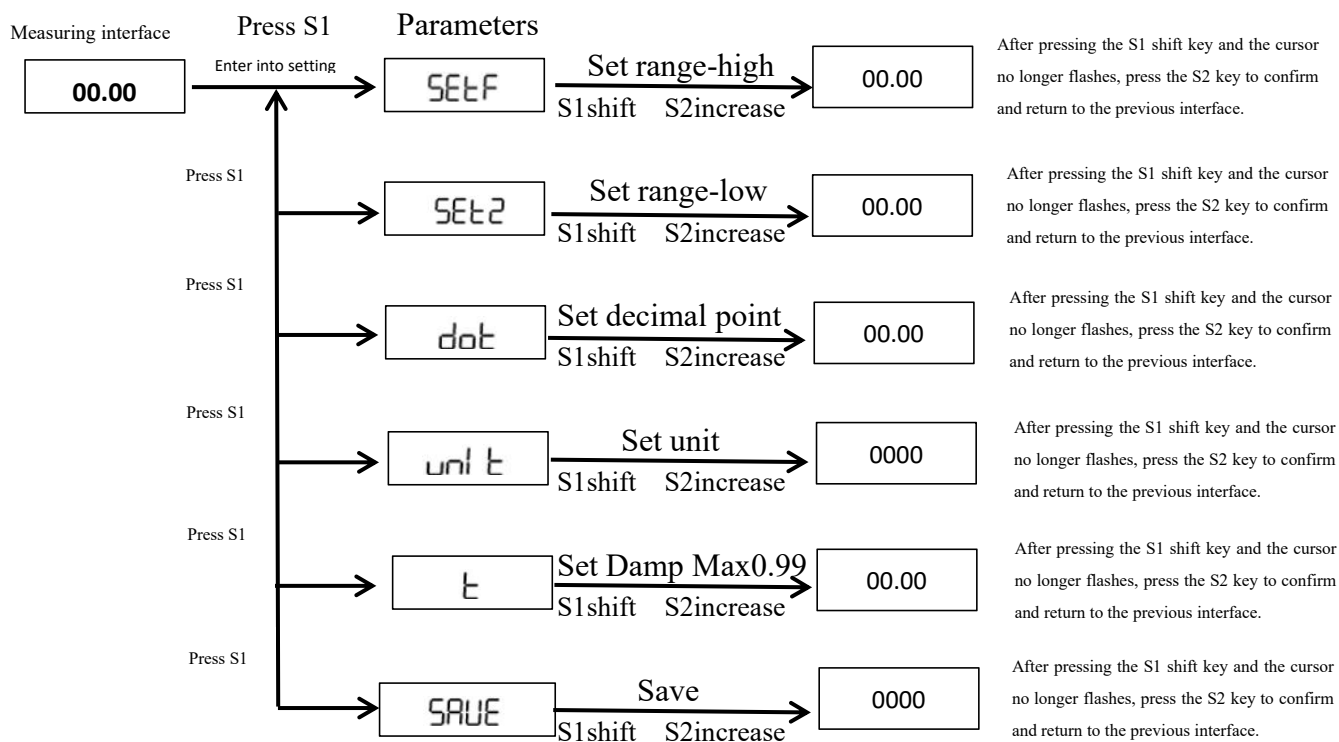

7.2 RS485 output mode

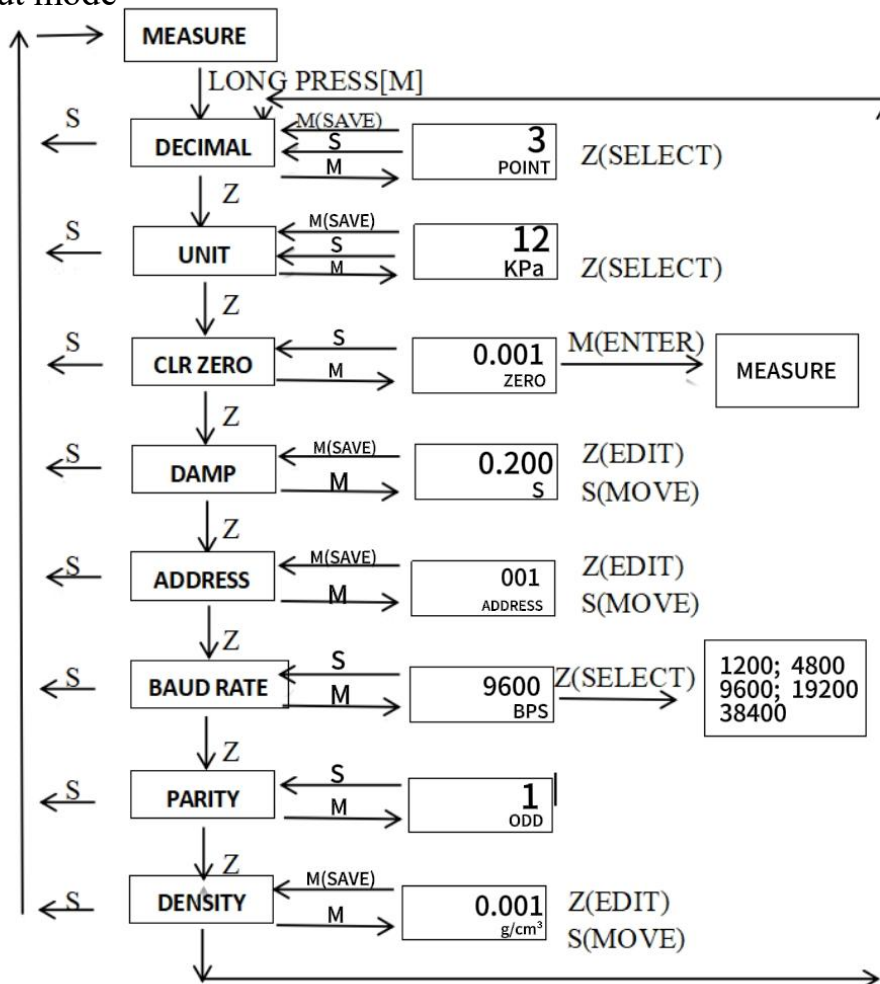

6. Communication description

The communication protocol of this instrument complies with the MODBUS-RTU communication protocol, with 1 start bit, 8 data bits, and 1 stop bit.

The following command defines the hypothetical instrument parameters: the instrument address is set to 1, the communication baud rate is 9600, the invalid check digit, the decimal point is 1 digit, the unit is MPa, and the instrument display value is 500.0MPa.

Read instruction

The address and data in the instruction are high byte first and low byte after; CRC check low byte first and high byte after.

Read pressure value

Command: 01 03 00 04 00 01 C5 CB

Instructions: 01 (instrument address) 03 (read command) 00 04 (instrument communication address) 00 01 (read a parameter) C5 CB (CRC16 verification code)

Response: 01 03 02 13 88 B5 12

Instructions: 01 (instrument address) 03 (read command) 02 (number of bytes read) 13 88 (13 88 is hexadecimal number, 13 high byte and 88 low byte are converted to decimal number to 5000) B5 12 (CRC16 verification code)

Read parameter value

Command: 01 03 XX XX 00 01 CRC1 CRC2

Instructions: 01 (instrument address) 03 (read command) XX XX (parameter address see Table 2) 00 01 (read a parameter) CRC1 CRC2 (CRC16 verification code: low byte first, high byte after)

Response: 01 03 02 XX XX CRC1 CRC2

Instructions: 01 (instrument address) 03 (read command) 02 (number of bytes read)

XX XX (Returned parameter value: high bit in front, low bit in back) CRC1 CRC2

(CRC16 validation code: low byte in front. High byte in back)

Writing parameter command

Command: 01 06 XX XX data1 data2 CRC1 CRC2

Instructions: 01 (instrument address) 06 (write command) XX XX (parameter address see table 2)

data1 data2 (data1 data2 write parameters: high byte first, low byte after, see table 2) CRC1 CRC2

(CRC16 verification code: low byte first, high byte after)

Response: 01 06 XX XX data1 data2 CRC1 CRC2

Instructions: 01 (instrument address) 06 (write command) XX XX (parameter address see table 2)

data1 data2 (data1 data2 write parameters: high byte first, low byte after, see table 2) CRC1 CRC2

(CRC16 verification code: low byte first, high byte after)

Table 2: Parameter address and data

Parameter	Content	Address (Hex)	Data (data1 data2)
Addr	Transmit address	00 00	1~255
baud	Transmitting board baud rate	00 01	1-2400 2-4800 3-9600 4-19200
Unit	Units of measurement	00 02	0-m 1-kpa 2-Mpa 3-°C 4-L 5-bar 6-psi 7-Pa
Dot	Number of decimal places of measurement data	00 03	Ranges: 0-4
value	Real-time display of values	00 04	
Zero	Zero drift	00 05	
Parity	Effectiveness	00 06	0-None 1-Odd 2-Even
Loc	Password verification	00 0A	Password: 38 79

Steps to write parameters

1. Password verification, the password is 38 79H, that is, send the command: 01 06 0A
38 79 7B EA

2. Write the parameters that need to be modified. For example, when changing the address of the transmitter board to 2, the command: 01 06 00 00 00 02 08 0B

Note: When writing parameters, password authentication only needs one time. In the case of uninterrupted power, other parameters can continue to be modified without re-authentication. After power off, you need to re-authenticate before you can modify the parameters.

485 message: Add: 1-247

01 03 00 04 00 01 C5 CB

02 03 00 04 00 01 C5 F8

03 03 00 04 00 01 C4 29

04 03 00 04 00 01 C5 9E