

80G radar water level gauge



型号：ZAXPULS-G86

Catalogue

1、 Product principle.....	1
2、 Characteristics of 80G radar water level gauge.....	1
3、 Instrument introduction.....	2
4、 Instrument Install.....	2
5、 Electrical connection	4
6、 Instrument debugging.....	5
7、 Structural dimension.....	6
8、 Instrument linearity.....	7
9、 Technical parameter.....	7

Frequency modulation radar water level gauge

1.Product principle:

The general principle of frequency modulated continuous wave radar water level meter is that the radar emits electromagnetic waves at the installation position, and the electromagnetic waves are received by the radar after the reflection of the medium. The frequency difference δf between the received signal and the transmitted signal is proportional to the distance R on the surface of the medium: $R = C \text{ (speed)} \cdot \delta f \text{ (frequency difference)} / 2 / K \text{ (frequency modulation slope)}$. Because the speed of light C and the frequency modulation slope K are known, the frequency difference δf can be calculated to obtain the distance R from the radar installation position to the liquid surface, and then subtract the space distance from the radar to the liquid surface through the known installation height (referred to as the air height) to obtain the height of the liquid level.

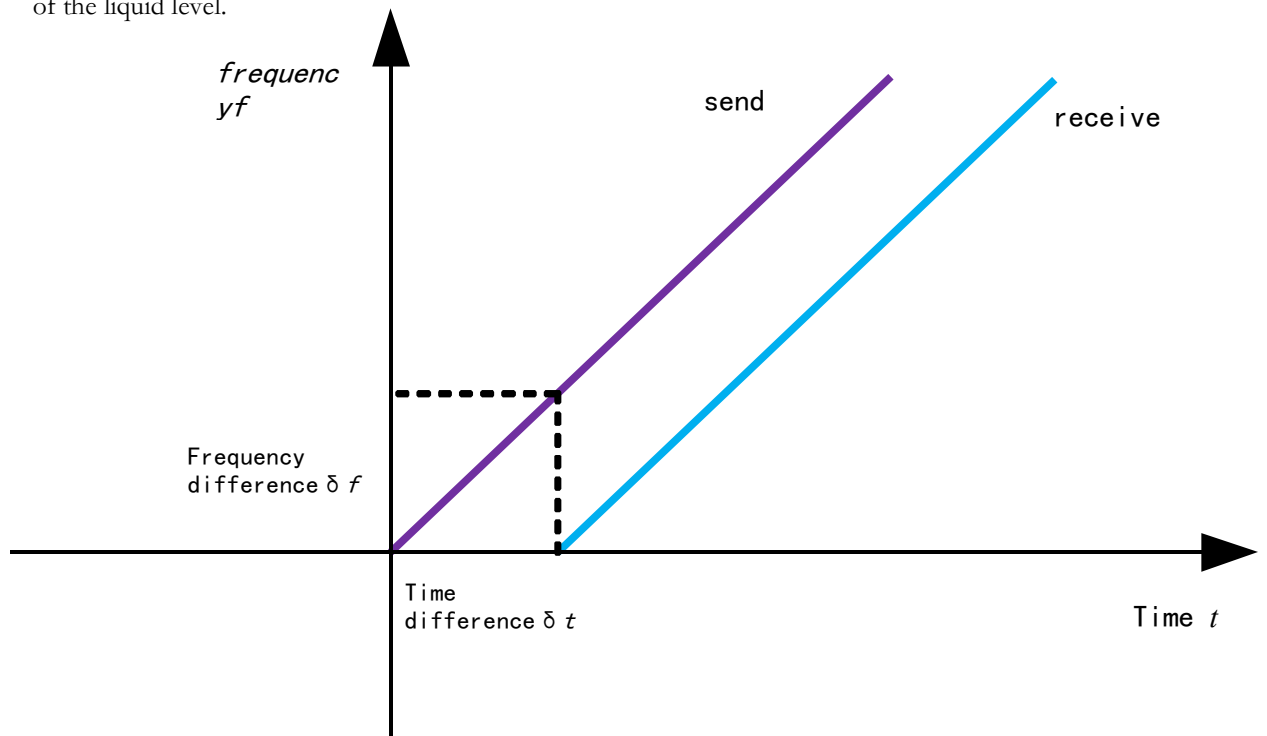

Time difference $\delta t = 2R / C \text{ frequency}$

Frequency difference $\delta f = K \cdot \delta t$

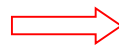

Distance $R = C \cdot \delta f / 2 / K$

Note: K is the frequency modulation slope

2、 Characteristics of 80G radar water level gauge

- (1) The beam Angle is small, the energy is concentrated, and it has stronger anti-interference ability and higher measurement accuracy
- (2) Small size, light weight, easy to install
- (3) Protection level up to IP68, suitable for a variety of water level measurement occasions
- (4) Measuring range up to 85 meters, covering large reservoirs and other water level measurement
- (5) A variety of output circuit interfaces cooperate with the acquisition system

3、 ZAXPULS-G86 Instrument introduction



Use: river, lake, shoal Measuring range: 0 ~ 85 m
Process connection: Dragon door frame, locking flange from DN50/ G2
Process temperature: -40 ~ 80°C
Process pressure: (-0.1 ~ 0.3) MPa
Precision: ± 2 mm
Frequency range: 76GHz ~ 81GHz
Protection level: IP68
Antenna size: 35mm lens
Power supply: 9-30VDC
Signal output: 4-20mA/RS485
Test: Bluetooth /Modbus protocol
Field debugging: wechat smallprogram
Port rate: 9600 (default)
Outer shell: PTFE/ABS

4、 ZAXPULS-G86 Instrument Install ❖

Preparations before installation

Please note the following to ensure that the meter is installed correctly Reserve enough space for installation.

Please avoid strong vibration installation site.

❖ Figure description and installation position

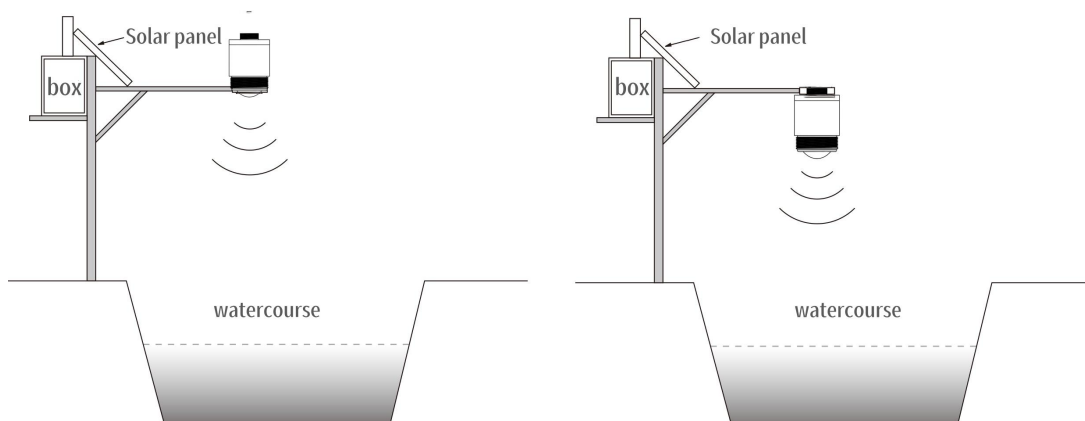

Radar water level meter installation diagram(1)

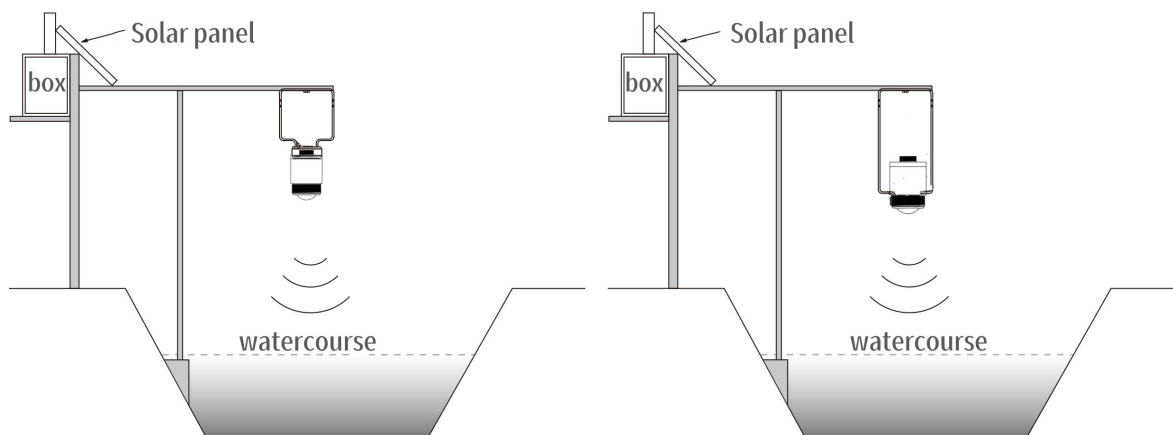

Radar water level meter installation diagram (2)

Note: When the radar antenna transmits electromagnetic waves, it has a certain emission Angle. There shall be no obstacles between the lower edge of the antenna and the surface of the measured medium, and within the area radiated by the transmitting electromagnetic wave beam. Therefore, the installation should avoid the blocking facilities as much as possible, and if necessary, "false echo learning" must be carried out. Note also when installing the instrument: the highest level must not enter the measurement blind area.

5、 ZAXPULS-G86 Electrical Connection

(1) Supply voltage

Modbus-RS485/ 4~20mA Power supply and RS485Modbus signal cables. For details about the power supply voltage range, see Technical data.

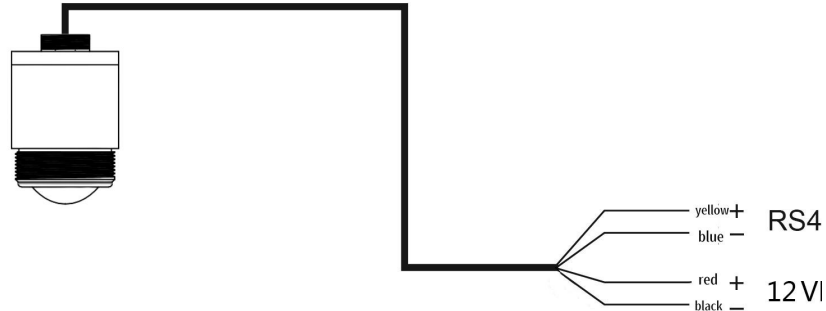

(2) Safety guidance

Please comply with the requirements of local electrical installation regulations!

Please follow local health and safety protocols.

All operations on the electrical components of the instrument must be performed by formally trained professionals.

Please check the nameplate of the instrument to ensure that the product specifications meet your requirements.

Ensure that the supply voltage is consistent with the requirements on the meter nameplate.

(3) Class of protection

This instrument fully meets the requirements of protection class IP68, please ensure that the cable sealing head is waterproof.

How to ensure installation meets IP68 requirements:

Make sure the seal head is not damaged. Make sure the cable is not damaged.

Ensure that the cables used meet the requirements of the electrical connection specifications.

Bend the cable down before entering the electrical interface to ensure that water does not flow into the housing.

Tighten the cable sealing head.

Plug the unused electrical interfaces with blind plugs

6、ZAXPULS-G86 Instrument Debugging

- There are two ways to debug a radar water level meter:
- Mobile Bluetooth debugging/Connect Bluetooth debugging radar through wechat mini program
- Host debugging/Debugging through MUDBUS

PC debugging: connected to the PC through the RS485 converter

- ① USB interface
- ② Radar water level gauge
- ③ RS485 converter

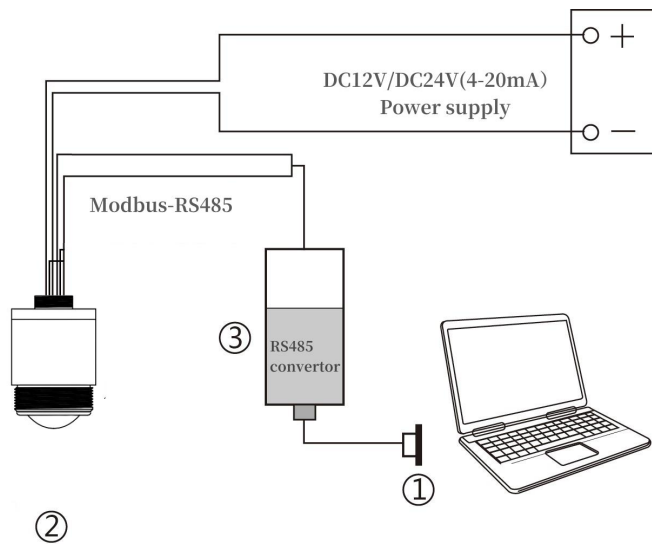

7、 ZAXPULS-G86 Structural dimension (Unit: mm)

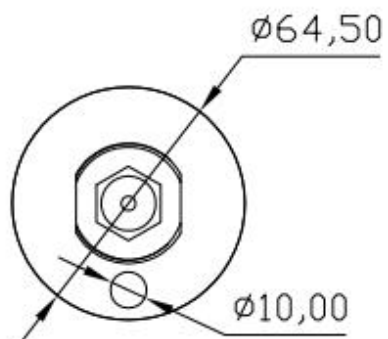
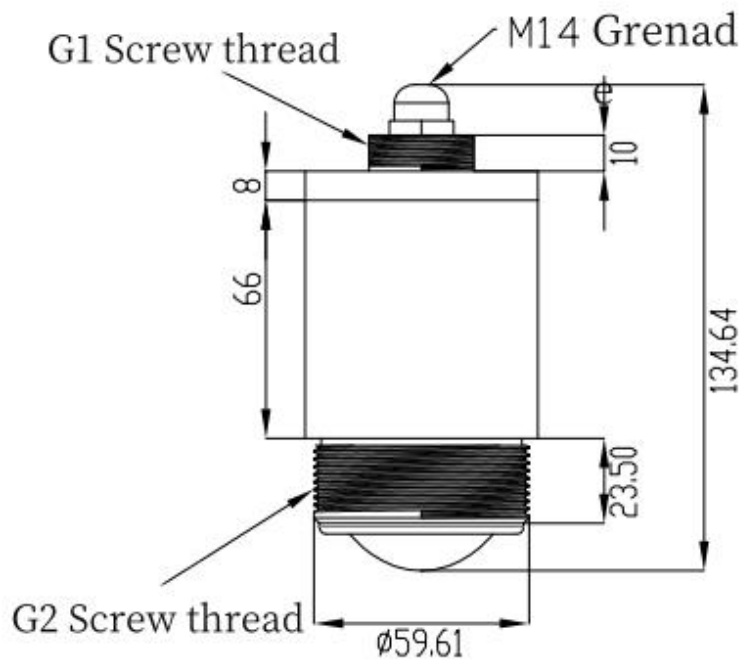

8、 ZAXPULS-G86 Instrument linearity

Beam diameter is a function of antenna type and measured distance:

Measuring distance	5M	10M	15M	20M	25M
Beam Angle width diameter	0.70M	1.40M	2.11M	2.81M	3.51M

The emission Angle depends on the antenna size

$\varphi 35\text{mm } 8^\circ$

See the following figure for accuracy

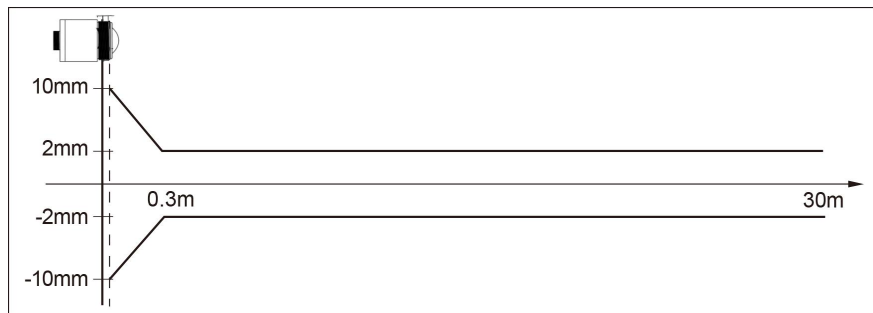

9、ZAXPULS-G86 Technical parameter

Shell material	PTFE/ABS
Seal between housing and housing cover	Silicone rubber
Two-wire system	24VDC/4-20mA
Four-wire system	12V DC / Modbus-RS485
Reserved cable	4 cores /5m
Output signal	4-20mA/RS485
Communication protocol	Modbus
Resolution	1mm
Dead zone	0.1 m
Maximum measuring distance	85m
Frequency modulation frequency	80GHz
Measuring interval	Up to 300ms (depends on parameter Settings)
Adjustment time	Auto
Display resolution	1mm
Working storage and transport temperature	(-40~80) °C
Process temperature (temperature of the antenna section)	(-40~80)°C
pressure	Atmospheric pressure
Shock resistance	Vibration frequency (10 ~ 150)Hz, maximum vibration acceleration 10m/s ²

Appendix

Radar level gauge consulting common parameters

Radar level gauge model: _____

Power supply requirement: _____

range: _____

Process temperature: _____

Process pressure: _____

Medium characteristic: _____

Antenna material requirements: _____

Other parts requirements: _____

remark: _____