



### **P Series Precise Mass Flow & Density Meter**

- Applied to Liquid, Gas, Slurry Mass Flow
- Mass Flow Accuracy  $\pm 0.1\%$  (Liquid) 、  $\pm 0.5\%$  (Gas)
- Density Measuring Accuracy  $\pm 1\text{kg/m}^3$
- Normal Diameter DN10~DN250
- Process Temperature Ranges  $-40^\circ\text{C}\sim+350^\circ\text{C}$

## **Component Parts of P Series Coriolis Mass Flow Meter**

P Series Coriolis Mass Flow Meter is defined as P series Mass Flow Meter with flow accuracy is 0.1%, whom is made of P series mass flow Sensor and DPT100 Transmitter.

## **Features and Benefits of P Series Coriolis Mass Flow Meter**

- Double U or double C type flow pipe design is better for measuring accuracy
- Provides integrated mass flow, volume flow, density, temperature measurement and the calculates the others relevant parameters
- Easy on installation, no need rectifier, filter parts, no special requirements for installing direct pipe section
- Without moving parts and no need frequent maintain; high stable function no need frequent calibration
- Allows low range flow running, reducing pressure loss to keep high efficiency
- Compact installation to save installation costs
- Being compatible with N series A(flanges faces interval distance) dimension
- Ultra precision measuring and long term stability functions for custody transfer measurement
- Ultra wide turndown ratio for gas measuring
- The connected Transmitter can be exchanged for easy maintain
- No being influenced by ambient temperature

## **Model Selection Principle**

- In the applied fields of Coriolis Mass Flow Meter, the Max. Flow rate is decided by pressure loss while the Min. Flow rate is decided by measuring accuracy
- Before selecting the product, the client or user should firstly refer to this manual, using the size selection software provided by ZAX TECHNOLOGY Co., Ltd., as well as the user should provide the relevant data such as accuracy, flow rate, pressure loss, density, viscosity, temperature, etc., which ensures the correct size selection and application. The software can be obtained from salespersons of the agency or downloaded from the company website: [www.zaxtechnology.com](http://www.zaxtechnology.com)

**Performance Index**

Liquid flow rate performance index.....1  
Gas measuring performance.....3  
Density performance index(only liquid).....4  
Temperature performance index.....5  
Power supply & Power consumption.....5

**Environmental Influences**.....6

**Usage Limits**

Pressure rating.....8  
Vibration limits.....9  
Safety & Protection.....9

**Structure Parameters**

Structure materials.....10  
Weight.....10  
Dimensions.....11

**Order Information**.....27

**Liquid Flow Rate Performance Index**

		<u>Mass flow rate</u>	<u>Volume flow rate<sup>[1]</sup></u>
		Kg/h	L/h
Maximum mass flow rate	P10	1500	1500
	P15	4500	4500
	P20	9450	9450
	P25	25500	25500
	P50	94500	94500
	P80	240000	240000
	P100	540000	540000
	P150	825000	825000
	P200	1650000	1650000
	P250	2700000	2700000
Mass flow accuracy <sup>[2]</sup>	15:1 within turndown <sup>[3]</sup>	±0.1%	
	15:1 beyond turndown	±(zero stability/instant rate)× 100%	
<hr/>			
Volume flow accuracy <sup>[2]</sup>	FS	±0.15± (Zero Stability / Instant Flow Rate) × 100%	
<hr/>			
Repeatability	15:1 within turndown	±0.05%	
	15:1 beyond turndown	± 1/2(Zero Stability / Instant Flow Rate)× 100%	
<b>Zero Stability</b>		Kg/h	
	P10	0.10	
	P15	0.30	
	P20	0.63	
	P25	1.70	
	P50	6.30	
	P80	16.0	
	P100	36.0	
	P150	55.0	
	P200	110.0	
P250	180.0		

[1]The criterion of volume flow rate is as per density. Regarding to the process liquid density isn't 1000kg/m<sup>3</sup>, the value of volume flow is value of maximum mass flow divided by liquid density.

[2]Flow Accuracy includes repeatability, linearity and hysteresis.

[3]Turndown is defined as the value of maximum flow divided by minimum flow.

**Accuracy, Turndown and Pressure Loss of P50  
connected with DPT100 Transmitter**

---

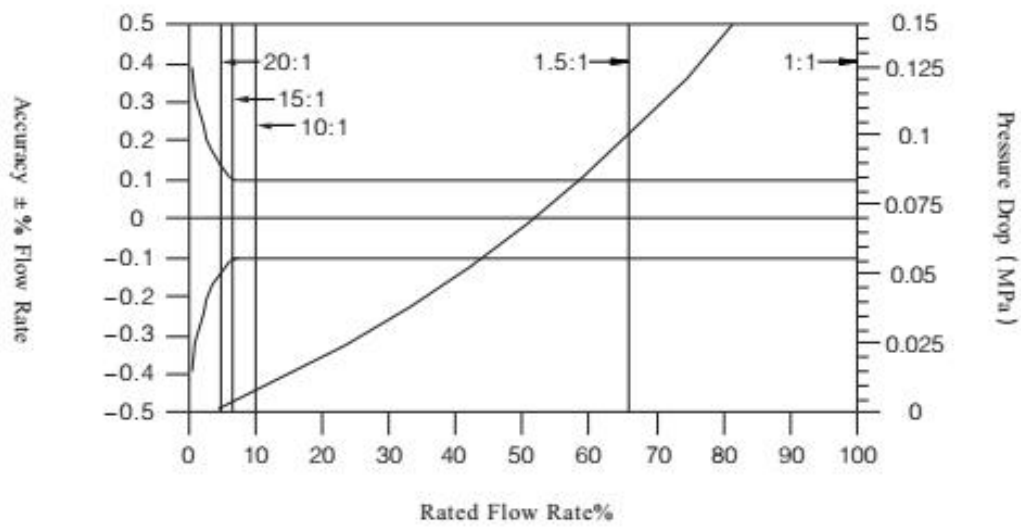

Turndown (from the maximum flow)	20:1	15:1	5:1	1.5:1	1:1
Accuracy $\pm$ %	0.14	0.1	0.1	0.1	0.1
Pressure Drop MPa	0.001	0.002	0.02	0.1	0.23

---

Note: when the maximum flow rate exceeds the given flow rate range, the noise from the pipe will affect the accuracy.

## Gas Measurement Performance

---

Mass flow accuracy	(flow rate > zero stability/0.005)	$\pm 0.5\%$
	(flow rate < zero stability/0.005)	$\pm(\text{zero stability}/\text{instant flow rate})\times 100\%$
Mass flow repeatability	(flow rate > zero stability/0.005)	$\pm 0.25\%$
	(flow rate < zero stability/0.005)	$\pm 1/2(\text{zero stability}/\text{instant flow rate})\times 100\%$

---

### ■ Standard Volume

In most application areas, customers are used to use standard volume to determine the volume under pressure and temperature, standard volume also called as "standard mass" flow unit to the fixed component liquid. Applied to the density under standard condition (receiving from reference data), flow meter would be output under the configuration of standard volume unit, which means that could be calculated between measured liquid quality and entrained liquid standard density, but no need the compensation of pressure, temperature and density. For more information pls. contact your local agency.

### ■ Pressure Loss

pressure loss is affected by the sensor geometric form, gas density and flow rate. While customers are suggested that the sensor pressure loss couldn't surpass 0.127Mpa when design type selection.

### ■ Flow Rate

The flow rate of gas measure is much greater than the flow rate of liquid measure, the higher flow rate leads to the noise will affect the signal of flow meter. So the flow rate within sensor pipe should be lower 0.5 times than sounds rate when the pressure loss of flow meter under 0.127Mpa.

---

## Accuracy and Pressure Loss Data Diagram of P50 Mass Flow Meter for Measuring different medium under different pressure

---

The curves of P50 mass flow meter pressure loss error

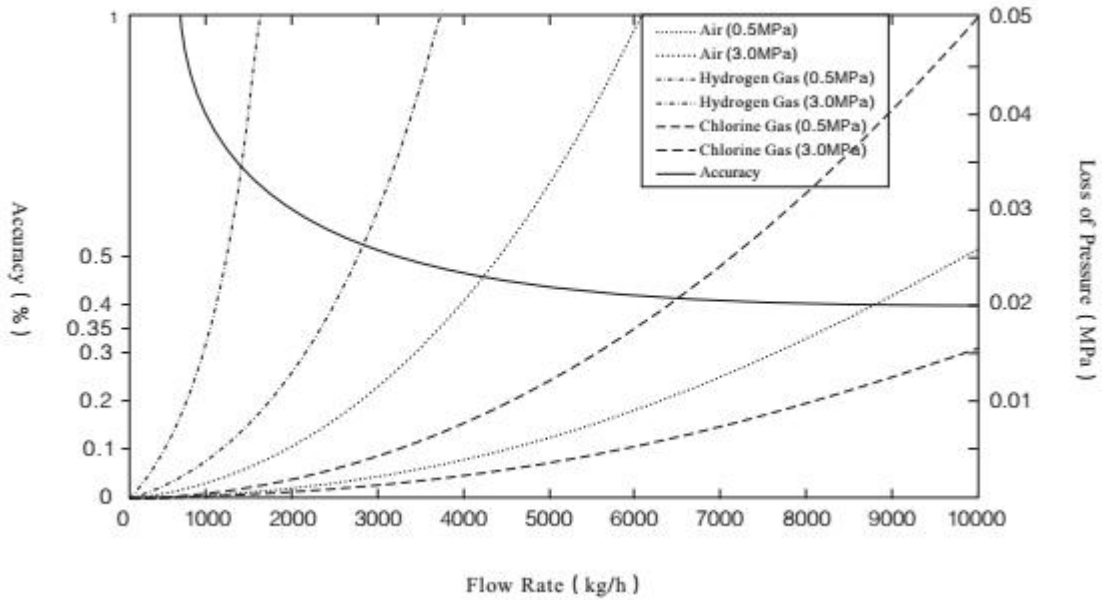

### Density Performance Index(only liquid)

---

Accuracy <sup>[1]</sup>	$\pm 0.001\text{g/cm}^3$	$\pm 1.0\text{kg/m}^3$
Repeatability	$\pm 0.0005\text{g/cm}^3$	$\pm 0.5\text{kg/m}^3$
Measuring Range	$0.2\sim 3.00\text{g/cm}^3$	$200\sim 3000\text{kg/m}^3$

---

[1] Flow Accuracy includes repeatability, linearity and hysteresis, density accuracy index of  $\pm 1.0\text{kg/m}^3$  is calculated under the condition of water of  $20^\circ\text{C}$  &  $-2\text{bar}$ .

## Temperature Performance Index

---

Accuracy	All Models	$\pm 0.5^{\circ}\text{C}$
Repeatability	All Models	$\pm 0.2^{\circ}\text{C}$
Temperature Limits <sup>[2]</sup>	All Models matched all Electronics options	

---

[2]Temperature Limits maybe need explosion protection for further limit because installed in hazardous area, refer P9.

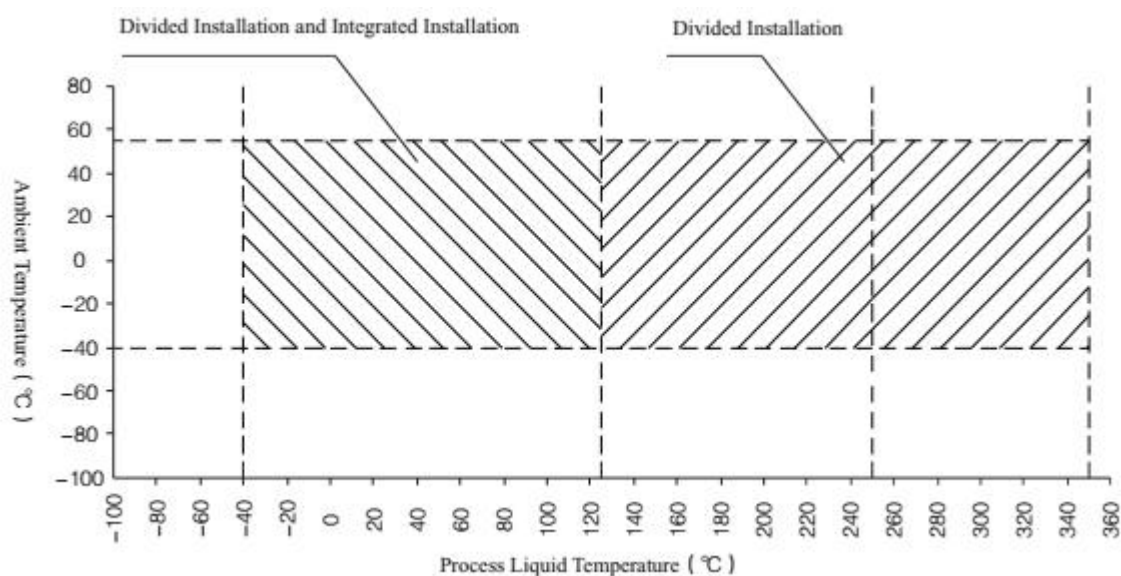

■ The temperature must be heated to the local ambient temperature between  $-40^{\circ}\text{C}\sim+55^{\circ}\text{C}$  (such as using steam tracing method) when the temperature below  $-40^{\circ}\text{C}$ .

Temperature Measuring Range:  $-50^{\circ}\text{C}\sim+350^{\circ}\text{C}$  (Use Pt100 temperature measurer)

---

Temperature of Measured Liquid:	Compact Installation	$-40^{\circ}\text{C}\sim+125^{\circ}\text{C}$
	Remote Installation	$-40^{\circ}\text{C}\sim+350^{\circ}\text{C}$

---

Ambient Temperature:	Storage	$-40^{\circ}\text{C}\sim+70^{\circ}\text{C}$
	Usage	$-40^{\circ}\text{C}\sim+55^{\circ}\text{C}$

---

## Power Supply & Power Consumption

---

Matched DPT100

Maximum 10W

For sensor P100 P150 P200 P250, the power amplifiers should be provided with extra power supply.  
220VAC (or 24VDC) power supply

Maximum 30W (20W)

---

Note: The DC Starting Current of Flow Meter is Less Than 1A(Without Power Amplifier).

## Process Temperature Influence

---

**Process Temperature Influence** Process Temperature Influence is defined as below:

- Regarding to Mass Flow Measurement, Process Temperature Influence is the maximum zero offset which is caused by the Process temperature deviates zero coordinate temperature.
- Regarding to Density Measurement, process temperature Influence is the maximum measurement deviation which is caused by the process temperature deviates density calibrated temperature.

Process Temperature Influence			
		%Maximum Flow Rate Value/°C	Density Accuracy/°C <sup>[1]</sup> (kg/m <sup>3</sup> )
<b>Maximum Error</b>	P10	±0.000125	±0.015
	P15	±0.000125	±0.015
	P20	±0.000125	±0.015
	P25	±0.000125	±0.015
	P50	±0.0005	±0.015
	P80	±0.0005	±0.015
	P100	±0.00075	±0.015
	P150	±0.00025	±0.015
	P200	±0.00025	±0.015
	P250	±0.00025	±0.015

---

## Pressure Influence

---

**Pressure Influence** Pressure Influence is defined as:

The changes of sensor flow and density sensibility is caused by process pressure deviates calibrated pressure. Pressure Influence can be amended.

	<u>flow accuracy influenced by pressure<sup>[1]</sup></u>	<u>density accuracy influenced by pressure<sup>[1]</sup></u>
	(% flow value / MPa)	(Kg/m3/ MPa )
<b>Pressure Influence</b>		
P10	-	-
P15	-	+0.58
P20	-	-0.29
P25	-0.03	-0.87
P50	-0.11	+0.145
P80	-0.25	+0.029
P100	-0.58	-1.45
P150	-0.35	-0.41
P200	-0.20	-0.37
P250	-0.14	-0.21

---

- The Data is achieved from pressure influence tests of flow rate, and the specific values are referred to the selection guide.
- The maximum calibrated pressure we apply in our factory is 0.4MPa.

## Pressure Rating

---

	<u>Normal Pressure</u>	<u>Max. Pressure</u>
	MPa	MPa
<b>flow tube pressure rating</b>		
P10	4	6.3
P15	4	6.3
P20	4	6.3
P25	4	6.3
P50	4	6.3
P80	4	6.3
P100	4	6.3
P150	4	6.3
P200	4	6.3
P250	4	6.3

The pressure(the unlisted temperature can be calculated by the linear insert method) should be lowered down as per the following terms if operating temperature surpass 148°C:

	flow tube	
	<u>316L Sensor</u>	<u>304 Sensor</u>
Less Than 148°C	null	null
204°C	low down 7.2%	low down 5.4%
260°C	low down 13.8%	low down 11.4%
316°C	low down 19.2%	low down 16.2%
343°C	low down 21.0%	low down 18.0%
371°C	low down 22.8%	low down 19.2%

---

## Vibration Limits

---

In accordance with the standard GB/T2423.11 . To bear 50 periods at the condition of  $a=1g(g=9.8m/s^2)$  and (20~500)Hz frequency to scan.

Suggested to apply remote installation if the application area vibration surpass  $a=0.5g$ .

## Safety & Protection

---

Tested and Issued certification by National Explosive-proof Electrical Products Quality Supervising and Testing Center:

**Explosion-proof Mark:** P10~ P80 Ex ib IIC T3~T6  
P100~P250 Ex ib IIC T6 Gb(T6 Includes T1 ~T6)

**Explosion-proof Certification No:** P10~P80 CNEEx 10.0468  
P100~P250 CNEEx 12.2660

**Protection Level:** IP67 (Sensor)

“T” temperature groups refer to the maximum surface temperature of the sensor at the working temperature of 55°C.

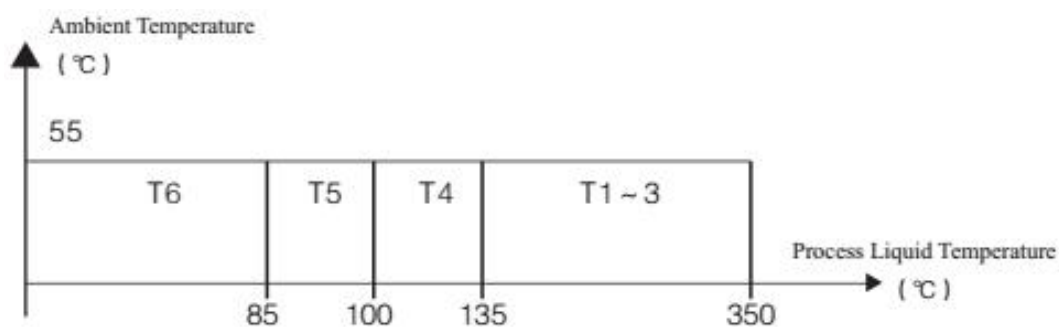

Explosion-proof performance is accordance with GB3836.1-2010、GB3836.3-2010、GB3836.4-2010.

Applications: applied in the explosive dangerous location zone 1 and zone 2, device type is IIC, which is compatible with IIA、IIB, temperature groups are T1~T6.

---

Note:The Ex-proof performance will not be affected by the installation of sensor and transmitter(remote or compact installation).

## Structure Material

---

<b>Wetted Parts</b>	Sensitive Pipe	00Cr17Ni14Mo2(316L)
	Separated Liquid	0Cr18Ni9(304)or 00Cr17Ni14Mo2(316L)
	Flange	0Cr18Ni9(304)or 00Cr17Ni14Mo2(316L)
<b>Cover</b>	Sensor	0Cr18Ni9(304)
	Transmitter	Cast aluminum alloy(coated polyester epoxy)
	Junction Box	Cast aluminum alloy(coated polyester epoxy)

## Weight

---

Weight: the weight refers to the mass flow meter welded the GB/T9115.1-2000 PN 40 welding neck flanges. The weight unit is (kg) .

---

Sensor Model	Compact Mount weight(kg)	Remote Mount weight(kg)
P10	9.5	6.5
P15	10.5	7.5
P20	14.0	11.0
P25	24.5	21.5
P50	50.0	46.0
P80	-	89.0
P100	-	208.0
P150	-	248.0
P200	-	365.0
P250	-	580.0

---

## Dimensions

### P10 Compact Installation

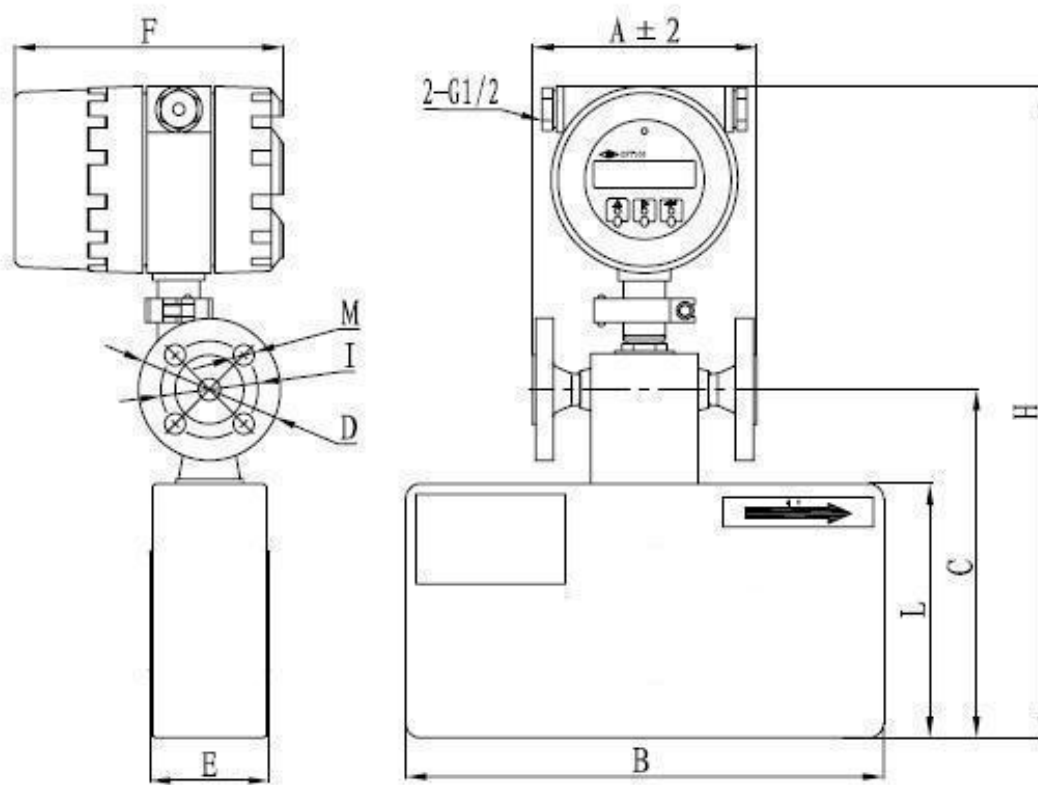

Note: The Listed Flanges In The Below Tables Are Welding-neck Steel Pipe Flanges RF

Flange(GB/T 9115-2010)		A	B	L	C	H	E	M	I	D	F
Flange(HG/T 20592-2009)											
DN(mm)	PN(MPa)										
15(Standard)	4.0	162	321	170	233	455	106	14	65	95	180
Flange(HG/T 20615-2009)		A	B	L	C	H	E	M	I	D	F
Flange(ASME B16.5-2009)											
DN (mm)	PN (Class)										
15(Optional)	300	192	321	170	233	455	106	16	66.7	95	180

## P10 Remote Installation

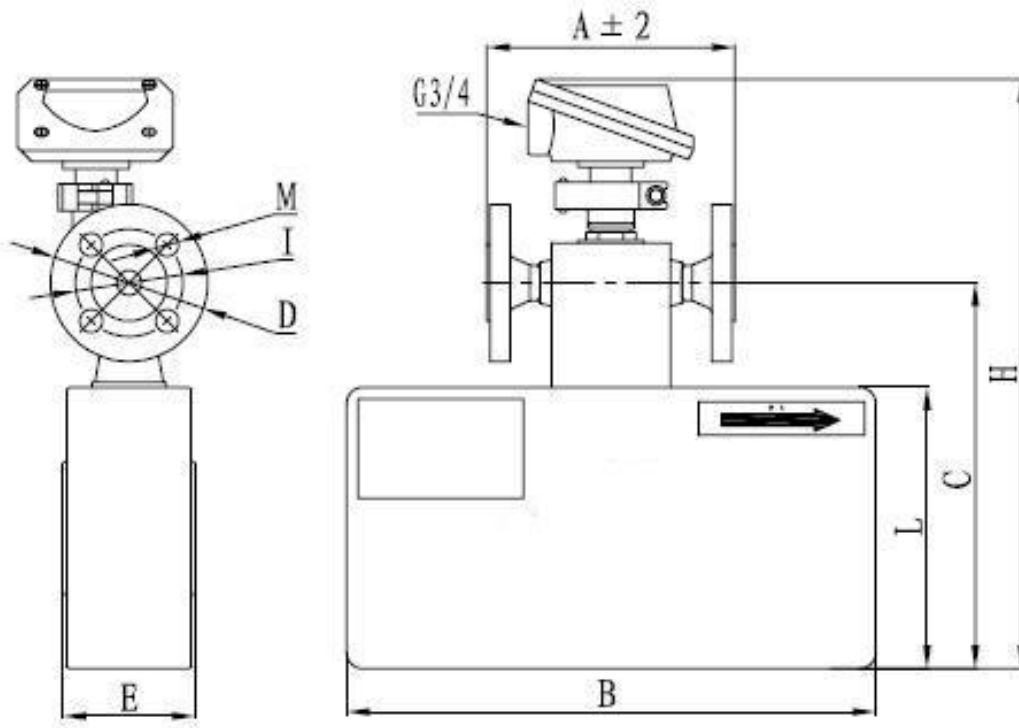

Note: The Listed Flanges In The Below Tables Are Welding-neck Steel Pipe Flanges RF

Flange(GB/T 9115-2010)		A	B	L	C	H	E	M	I	D
Flange(HG/T 20592-2009)										
DN(mm)	PN(MPa)									
15(Standard)	4.0	162	321	170	233	380	106	14	65	95
Flange(HG/T 20615-2009)		A	B	L	C	H	E	M	I	D
Flange(ASME B16.5-2009)										
DN(mm)	PN(Class)									
15(Optional)	300	192	321	170	233	380	106	16	66.7	95

## P15 Compact Installation

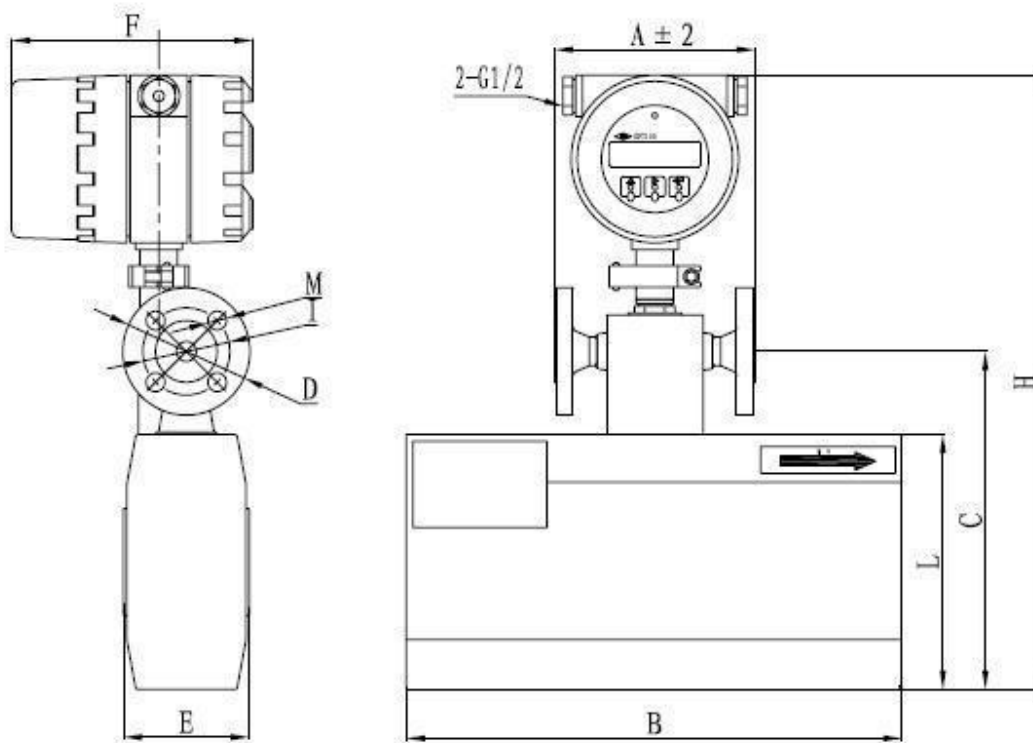

Note: The Listed Flanges In The Below Tables Are Welding-neck Steel Pipe Flanges RF

Flange(GB/T 9115-2010)		A	B	L	C	H	E	M	I	D	F
DN(mm)	PN(MPa)										
15(Standard)	4.0	162	370	190	252	477	124	14	65	95	180

Flange(HG/T 20615-2009)		A	B	L	C	H	E	M	I	D	F
DN(mm)	PN(Class)										
15(Optional)	300	192	370	190	252	477	124	16	66.7	95	180

## P15 Remote Installation

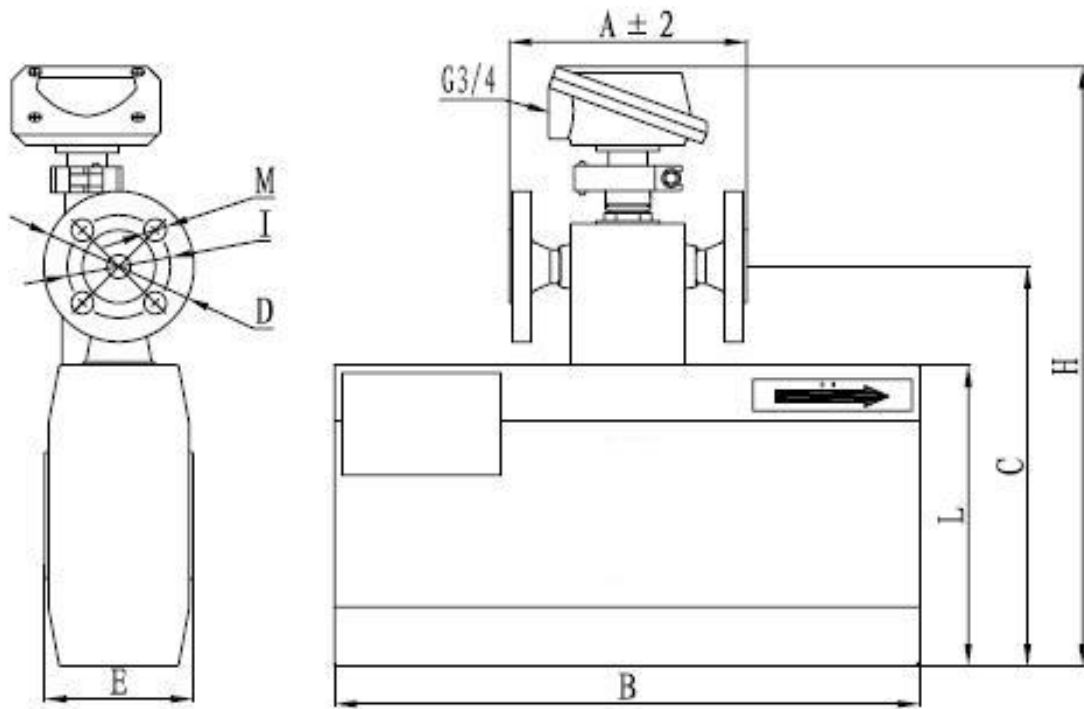

Note: The Listed Flanges In The Below Tables Are Welding-neck Steel Pipe Flanges RF

Flange(GB/T 9115-2010)		A	B	L	C	H	E	M	I	D
Flange(HG/T 20592-2009)										
DN(mm)	PN(MPa)									
15(Standard)	4.0	162	370	190	252	400	124	14	65	95
Flange(HG/T 20615-2009)		A	B	L	C	H	E	M	I	D
Flange(ASME B16.5-2009)										
DN(mm)	PN(Class)									
15(Optional)	300	190	370	190	252	400	124	16	66.7	95

## P20 Compact Installation

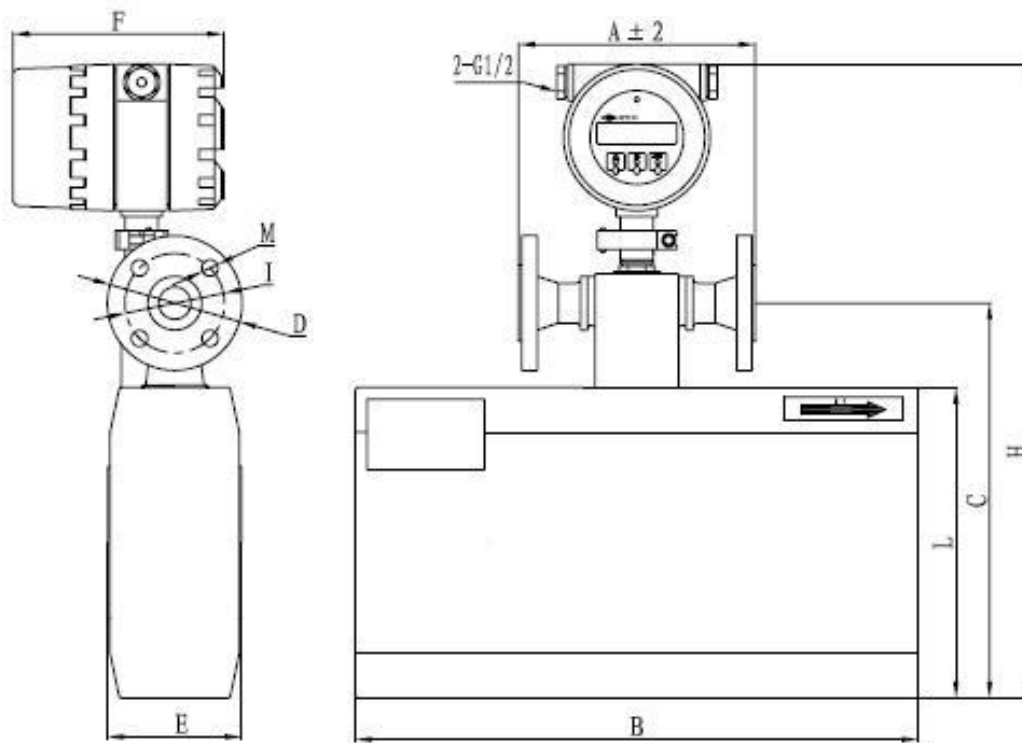

Note: The Listed Flanges In The Below Tables Are Welding-neck Steel Pipe Flanges RF

Flange(GB/T 9115-2010)		A	B	L	C	H	E	M	I	D	F
DN(mm)	PN(MPa)										
25(Standard)	4.0	202	480	265	337	550	134	14	85	115	180

Flange(HG/T 20615-2009)		A	B	L	C	H	E	M	I	D	F
DN(mm)	PN(Class)										
25(Optional)	300	246	480	265	337	550	134	18	88.9	125	180

## P20 Remote Installation

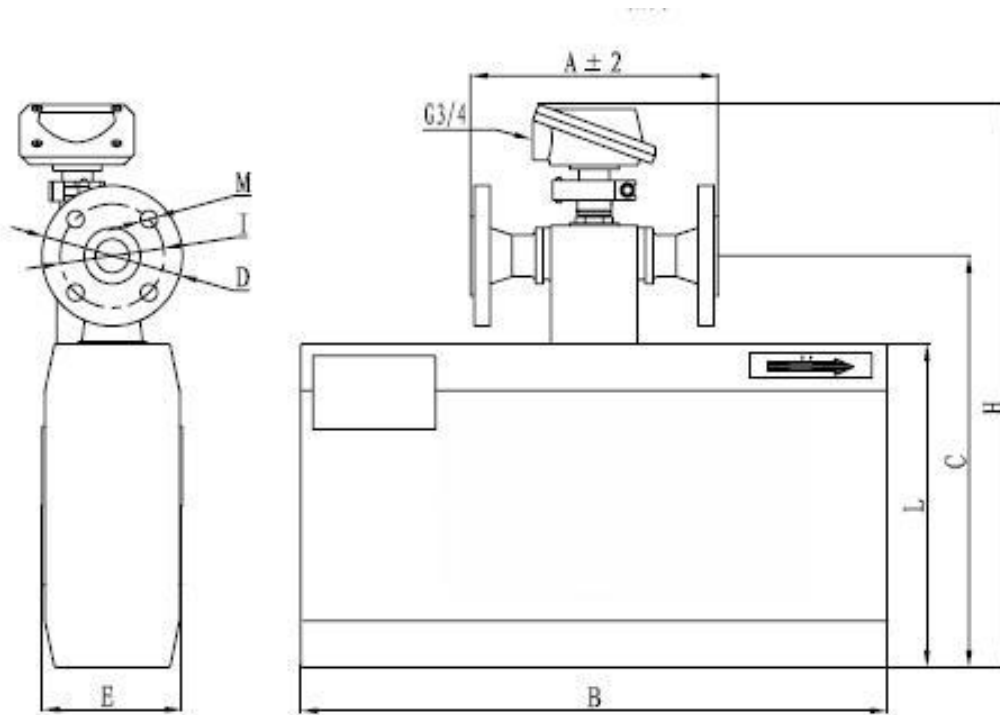

Note: The Listed Flanges In The Below Tables Are Welding-neck Steel Pipe Flanges RF

Flange(GB/T 9115-2010)		A	B	L	C	H	E	M	I	D
Flange(HG/T 20592-2009)										
DN(mm)	PN(MPa)									
25(Standard)	4.0	202	480	265	337	477	134	14	85	115

Flange(HG/T 20615-2009)		A	B	L	C	H	E	M	I	D
Flange(ASME B16.5-2009)										
DN(mm)	PN(Class)									
25(Optional)	300	246	480	265	337	477	134	18	88.9	125

## P25 Compact Installation

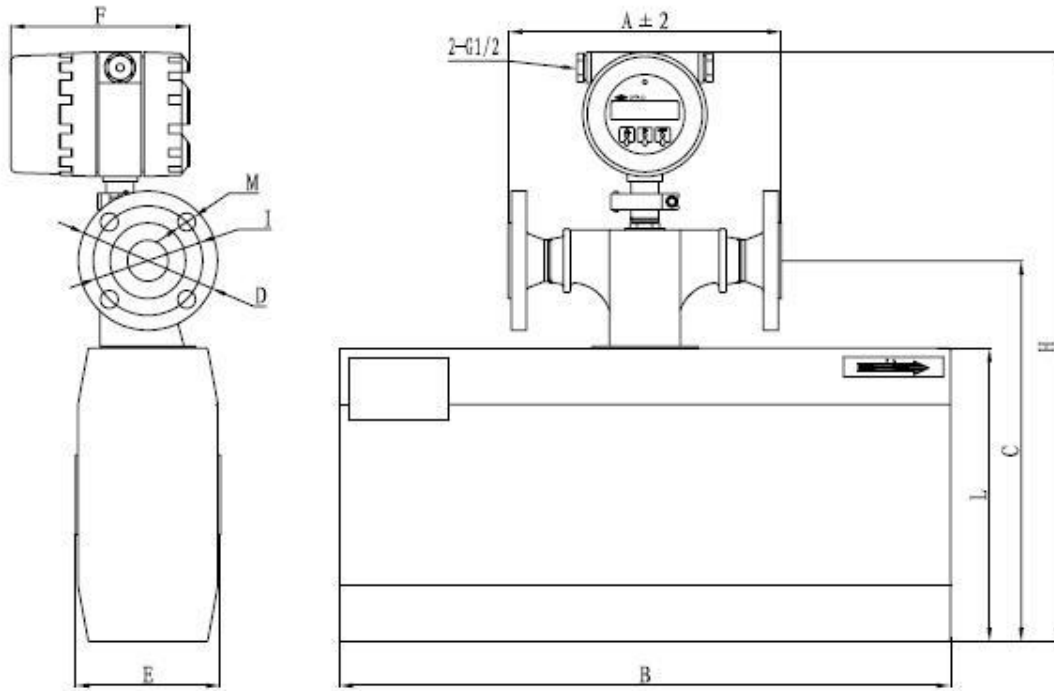

Note: The Listed Flanges In The Below Tables Are Welding-neck Steel Pipe Flanges RF

Flange(GB/T 9115-2010)		A	B	L	C	H	E	M	I	D	F
DN(mm)	PN(MPa)										
40(Standard)	4.0	274	615	295	383	579	146	18	110	150	180

Flange(HG/T 20615-2009)		A	B	L	C	H	E	M	I	D	F
DN(mm)	PN(Class)										
40(Optional)	300	320	615	295	383	579	146	22	114.3	155	180

## P25 Remote Installation

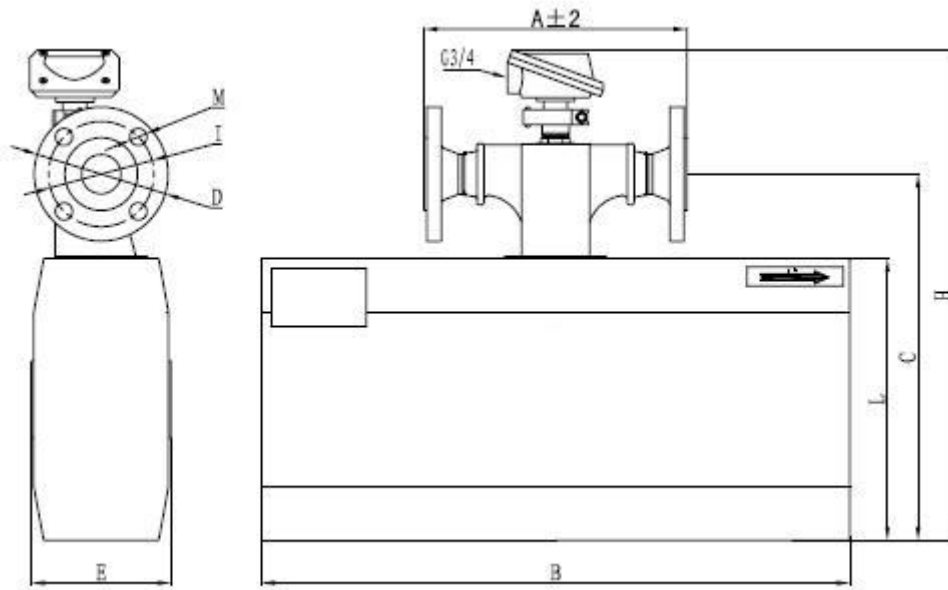

Note: The Listed Flanges In The Below Tables Are Welding-neck Steel Pipe Flanges RF

Flange(GB/T 9115-2010)		A	B	L	C	H	E	M	I	D
DN(mm)	PN(MPa)									
40(Standard)	4.0	274	615	295	383	516	146	18	110	150

Flange(HG/T 20615-2009)		A	B	L	C	H	E	M	I	D
DN(mm)	PN(Class)									
40(Optional)	300	320	615	295	383	516	146	22	114.3	155

## P50 Compact Installation

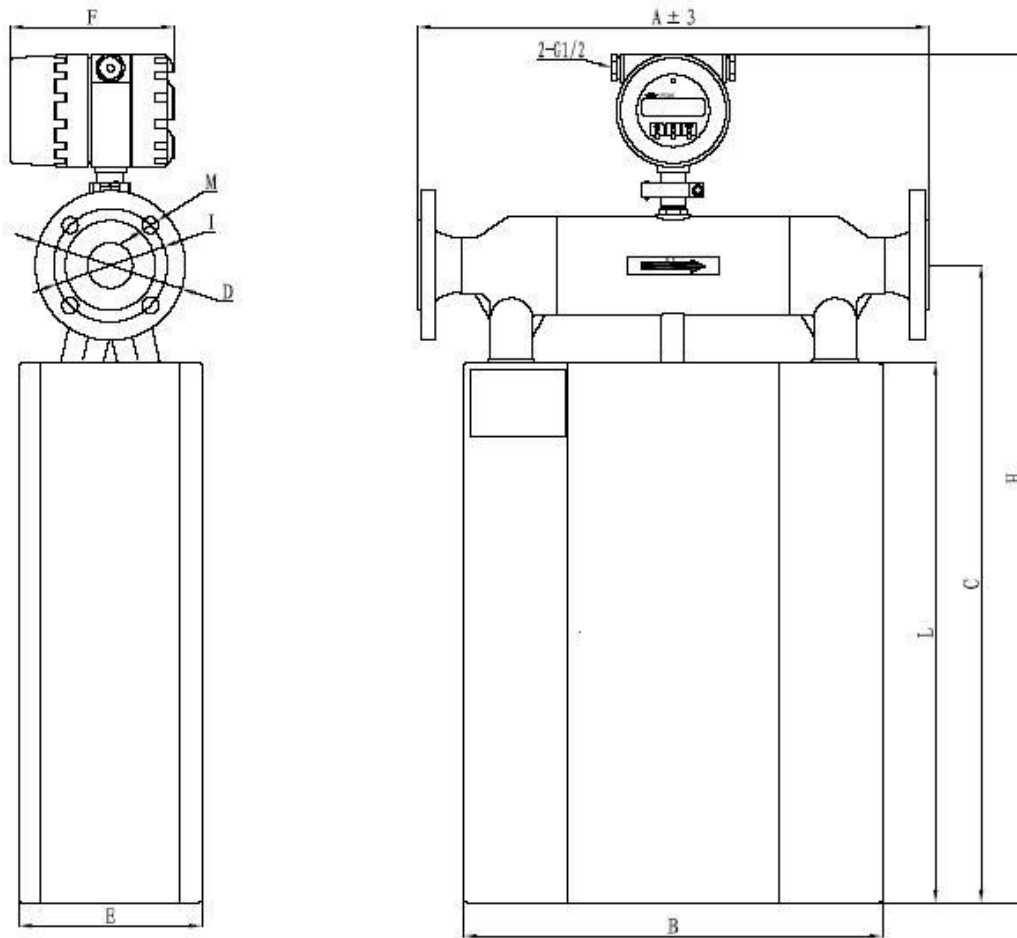

Note: The Listed Flanges In The Below Tables Are Welding-neck Steel Pipe Flanges RF

Flange(GB/T 9115-2010)		A	B	L	C	H	E	M	I	D	F
DN(mm)	PN(MPa)										
50(Standard)	4.0	562	460	595	702	922	201	18	125	165	180
65(Optional)	4.0	570	460	595	702	922	201	18	145	185	180

Flange(HG/T 20615-2009)		A	B	L	C	H	E	M	I	D	F
DN(mm)	PN(Class)										
50(Standard)	300	606	460	595	702	922	201	18	127	165	180
65(Optional)	300	620	460	595	702	922	201	22	149.2	190	180

## P50 Remote Installation

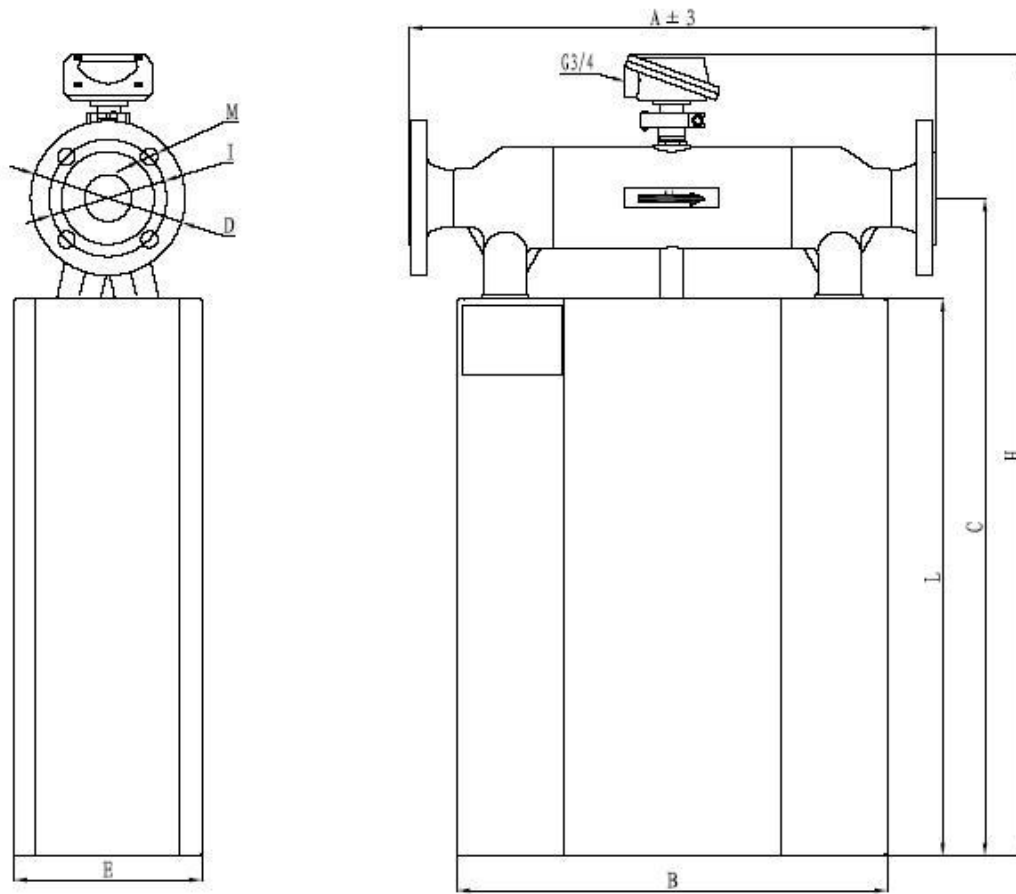

Note: The Listed Flanges In The Below Tables Are Welding-neck Steel Pipe Flanges RF

Flange(GB/T 9115-2010)		A	B	L	C	H	E	M	I	D
DN(mm)	PN(MPa)									
50(Standard)	4.0	562	460	595	702	845	201	18	125	165
65(Optional)	4.0	570	460	595	702	845	201	18	145	185

Flange(HG/T 20615-2009)		A	B	L	C	H	E	M	I	D
DN(mm)	PN(Class)									
50(Standard)	300	606	460	595	702	845	201	18	127	165
65(Optional)	300	620	460	595	702	845	201	22	149.2	190

### P80 Mass Flow Sensor

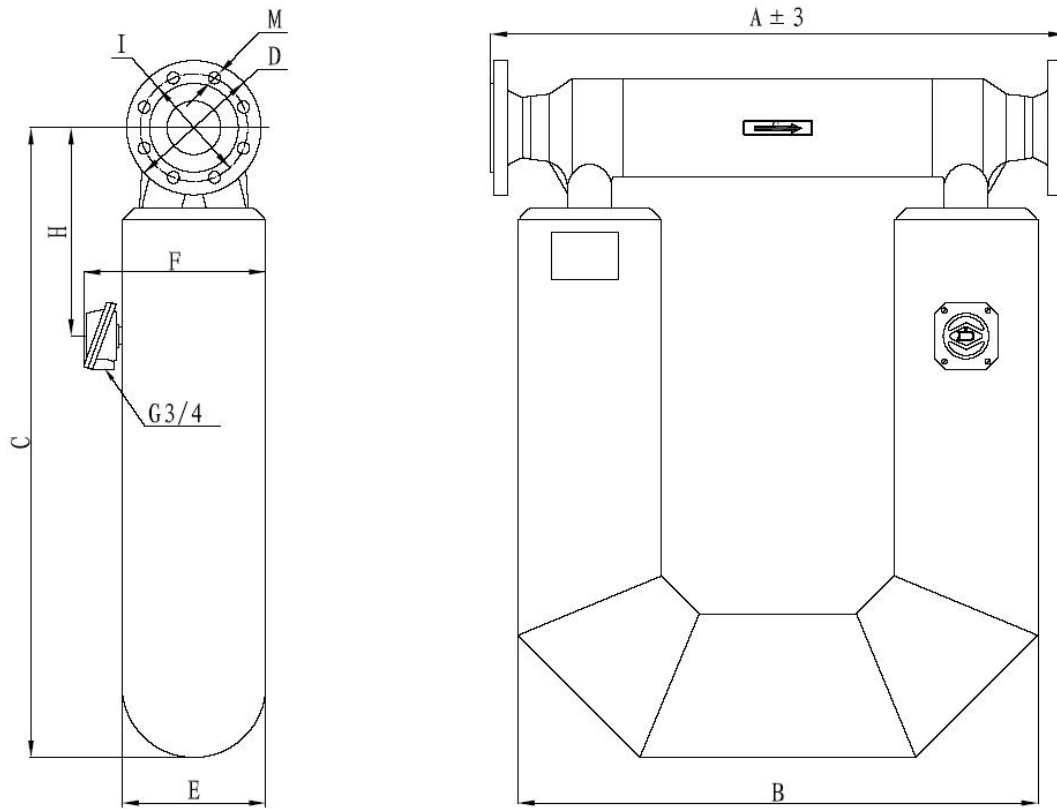

Note: The Listed Flanges In The Below Tables Are Welding-neck Steel Pipe Flanges RF

Flange(GB/T 9115-2010)		A	B	C	D	E	F	H	I	M
Flange(HG/T 20592-2009)										
DN(mm)	PN(MPa)									
80(Standard)	4.0	850	774	941	200	214	277	313	160	18
100(Optional)	4.0	864	774	941	235	214	277	313	190	22

Flange(HG/T 20615-2009)		A	B	C	D	E	F	H	I	M
Flange(ASME B16.5-2009)										
DN(mm)	PN(Class)									
80(Optional)	300	892	774	941	210	214	277	313	168.3	22
100(Optional)	300	904	774	941	255	214	277	313	200	22

## P100 Mass Flow Sensor

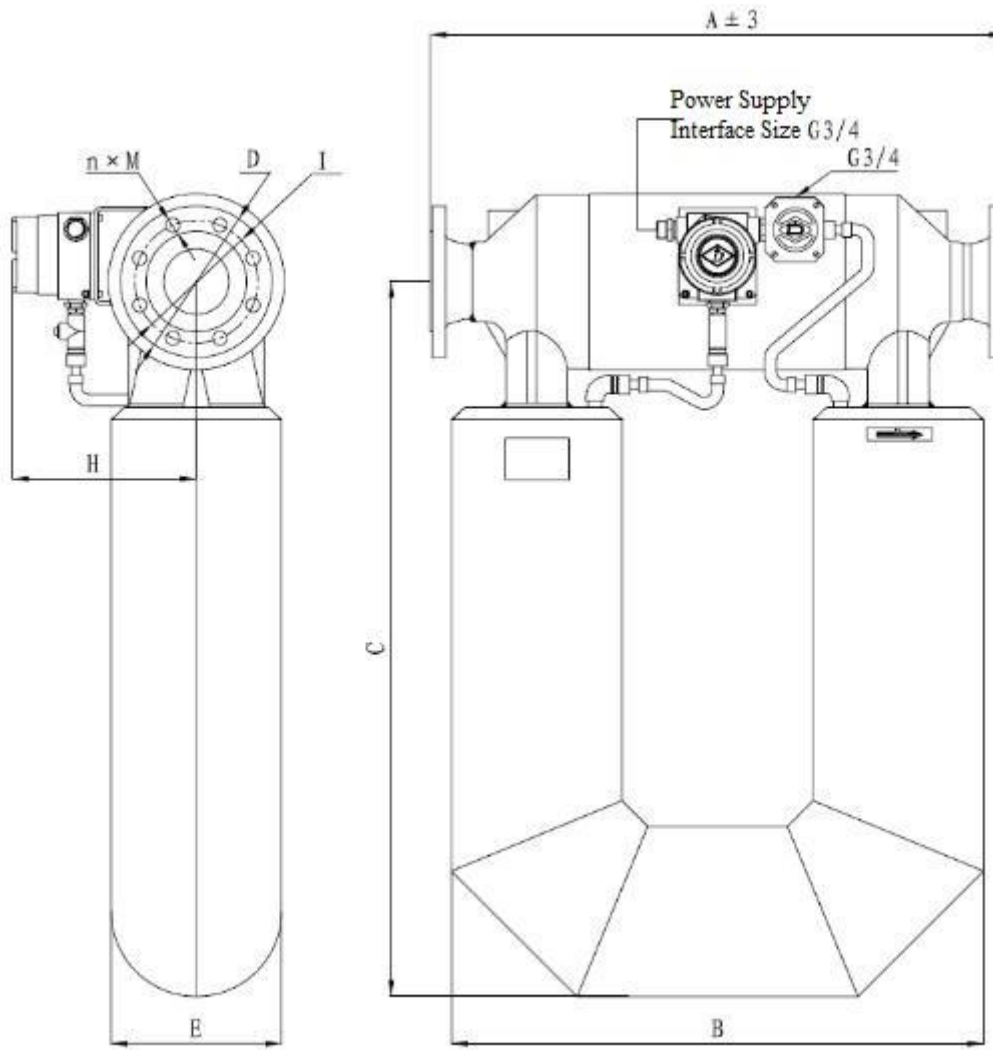

Note: The Listed Flanges In The Below Tables Are Welding-neck Steel Pipe Flanges RF

Flange(GB/T 9115-2010)		A	B	C	D	E	H	I	M	n
Flange(HG/T 20592-2009)										
DN(mm)	PN(MPa)									
100(Standard)	4.0	890	824	1135	235	264	287	190	22	8
150(Optional)	4.0	910	824	1135	300	264	287	250	26	8

Flange(HG/T 20615-2009)		A	B	C	D	E	H	I	M	n
Flange(ASME B16.5-2009)										
DN(mm)	PN(Class)									
100(Optional)	300	932	824	1135	255	264	287	200	22	8
150(Optional)	300	956	824	1135	320	264	287	269.9	22	12

# P150 Mass Flow Sensor

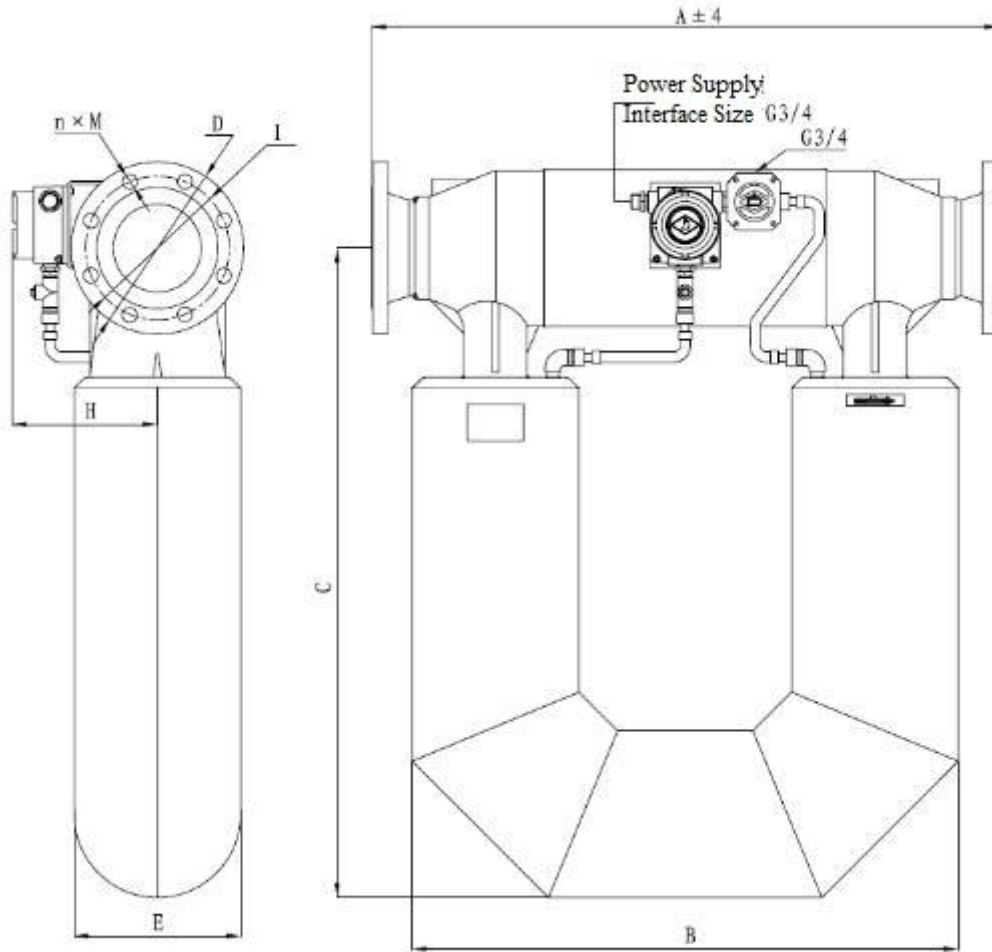

Note: The Listed Flanges In The Below Tables Are Welding-neck Steel Pipe Flanges RF

Flange(GB/T 9115-2010)		A	B	C	D	E	H	I	M	n
Flange(HG/T 20592-2009)										
DN(mm)	PN(MPa)									
150(Standard)	4.0	1090	950	1130	300	290	287	250	26	8
200(Optional)	4.0	1116	950	1130	375	290	287	320	30	12

Flange(HG/T 20615-2009)		A	B	C	D	E	H	I	M	n
Flange(ASME B16.5-2009)										
DN(mm)	PN(Class)									
150(Optional)	300	1136	950	1130	320	290	287	269.9	22	12
200(Optional)	300	1162	950	1130	380	290	287	330.2	26	12

## P200 Mass Flow Sensor

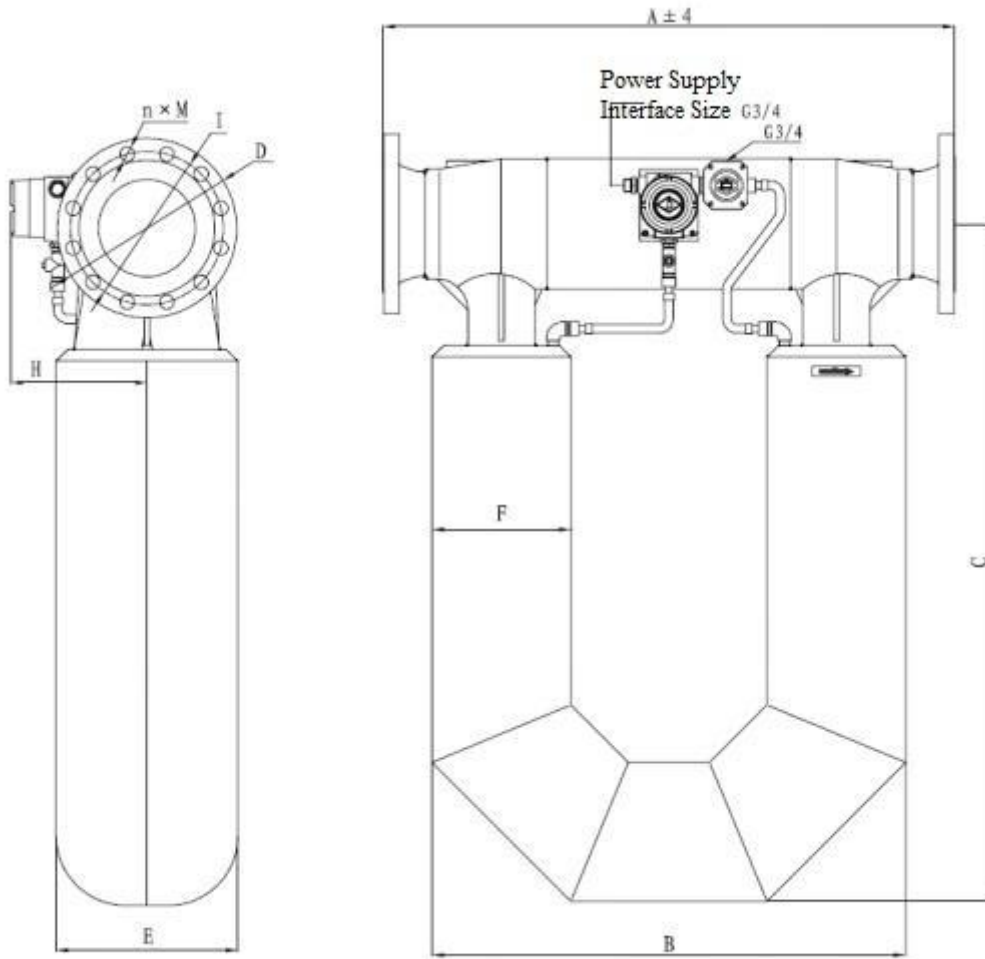

Note: The Listed Flanges In The Below Tables Are Welding-neck Steel Pipe Flanges RF

Flange(GB/T 9115-2010)		A	B	C	E	F	H	M	I	D	n
Flange(HG/T 20592-2009)											
DN(mm)	PN(MPa)										
200(Standard)	4.0	1206	1005	1407	380	290	287	30	320	375	12
250(Optional)	4.0	1240	1005	1407	380	290	287	33	385	450	12

Flange(HG/T 20615-2009)		A	B	C	E	F	H	M	I	D	n
Flange(ASME B16.5-2009)											
DN(mm)	PN(Class)										
200(Optional)	300	1252	1005	1407	380	290	287	26	330.2	380	12
250(Optional)	300	1264	1005	1407	380	290	287	30	387.4	445	16

## P250 Mass Flow Sensor

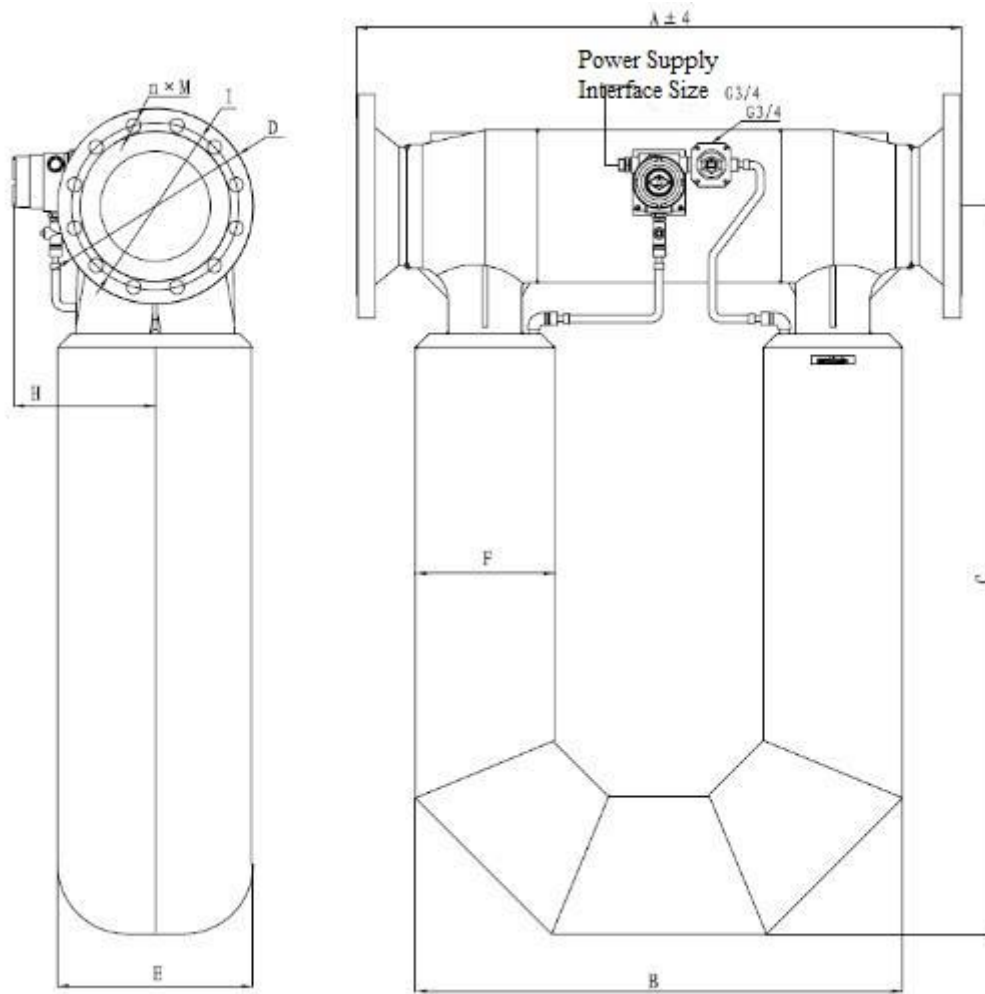

Note: The Listed Flanges In The Below Tables Are Welding-neck Steel Pipe Flanges RF

Flange(GB/T 9115-2010)		A	B	C	E	F	H	M	I	D	n
DN(mm)	PN(MPa)										
250(Standard)	4.0	1360	1120	1683	448	290	328	33	385	450	12
300(Optional)	4.0	1380	1120	1683	448	290	328	33	450	515	16

Flange(HG/T 20615-2009)		A	B	C	E	F	H	M	I	D	n
DN(mm)	PN(Class)										
250(Optional)	300	1382	1120	1683	448	290	328	30	387.4	445	16
300(Optional)	300	1408	1120	1683	448	290	328	33	450.8	520	16

**Note:**

For the model P100、P150、P200、P250, the ambient temperature of the power amplifiers is  $-20^{\circ}\text{C}\sim+55^{\circ}\text{C}$ , it is not allowed to cover or wrap, nor apply heat tracing to the power amplifiers in the process of heat tracing, otherwise the internal components will be damaged.

## Order Information

Options	Codes	Codes Description
Sensor Model□	P	P Series
	5	(0~350)kg/h
	10	(0~1500)kg/h
	15	(0~4500)kg/h
	20	(0~9450)kg/h
	25	(0~25500)kg/h
	50	(0~94500)kg/h
	80	(0~240000)kg/h
	100	(0~540000)kg/h
	150	(0~825000)kg/h
	200	(0~1650000)kg/h
	250	(0~2700000)kg/h
Transmitter Model□□□□	W000	None
	D102	DPT100 【English Display、IP67、Ex d e ib IIC T6 NF、Remote Type】
	D103	DPT100 【English Display、IP67、Ex d e ib IIC T6 NF、Compact Type】
	D104	DPT100 【Russian Display、IP67、Ex d e ib IIC T6 NF、Remote Type】
	D105	DPT100 【Russian Display、IP67、Ex d e ib IIC T6 NF、Compact Type】
Sensor Characters□	B	304&316L
	C	316L High Temperature of 350°C
	L	316L
	H	C-22
	T	Specified
Power Supply□	0	None
	1	18VDC-36VDC
	2	85VAC-265VAC
	3	Intelligent Type
Process	A	GB/T 9124.1    welding neck flanges    4MPa    WN-RF

	C	GB/T 9124.1	welding neck flanges	6.3MPa	WN-RF
	E	HG/T 20615	welding neck flanges	Class300	WN-RF
	F	ASME B16.5	welding neck flanges	Class150	WN-RF
	G	ASME B16.5	welding neck flanges	Class300	WN-RF
	I	HG/T 20592	welding neck flanges	4MPa	WN-RF
	T	Specified			

Options	Codes	Codes Description
Size	B	DN15
	D	DN25
	F	DN40
	G	DN50
	H	DN65
	I	DN80
	J	DN100
	L	DN150
	M	DN200
	N	DN250
	O	DN300
	T	Specified
Accessories□	0	None
	1	10m cable
	2	Carbon steel flanges, bolts and nuts, metal winding gaskets, 5m cable
	3	Stainless steel flanges, bolts and nuts, metal winding gaskets, 5m cable
	4	Carbon steel flanges, bolts and nuts, metal winding gaskets
	5	Stainless steel flanges, bolts and nuts, metal winding gaskets
	9	Specified
Electrical Interfaces□	W	None
	M	M20×1.5
	N	1/2NPT
	P	3/4NPT
	G	G1/2
	E	G3/4
	T	Specified
Communications □	0	None
	1	Active Current (4~20)mA、 Active Frequency(0~10)kHz、 RS-485
	2	Active Current(4~20)mA、 RS-485
	3	Active Frequency(0~10)kHz、 RS-485
	4	Passive Frequency(0~10)kHz、 RS-485
	5	Active Frequency(0~10)kHz、 Passive Current(4~20)mA+ HART(DPT)
	6	Active Frequency(0~10)kHz、 Active Current(4~20)mA+ HART(DPT)

	7	Passive Frequency(0~10)kHz、 Active Current(4~20)mA+ HART(DPT)
	8	Passive Frequency(0~10)kHz、 Passive Current(4~20)mA+ HART(DPT)
	9	Specified
Measuring Modes□	G	Custody Transfer Measuring
	B	General Measuring Type
	D	Gas Measurement Type
	Z	Undefined