

THERMAL MASS FLOW METER

« User Manual



(Version 21)



CONTENT

Safety Information.....	01
Part 1 Introduction.....	04
Part 2 Specification.....	05
Part 3 Mechanical Construction	07
3.1 Appearance	07
3.2 Dimension for Thermal Mass Flow Meter	08
Part 4 Wiring	09
4.1 Instruction of Sensor Wiring.....	09
4.2 Instruction of Transmitter Wiring.....	10
4.3 The Wiring of Power Supply.....	10
Part 5 Installation	12
5.1 Installation Position.....	12
5.2 Pipework requirements.....	15
5.3 Installation Steps.....	15
Part 6 Operation and Programming.....	17
6.1 Display.....	17
6.2 Parameters Setup	18
Appendix 1 Troubleshooting and Repair.....	27
Appendix 2 The Density and Conversion Coefficient of Common Gas	29
Appendix 3 Upper Range Value of Common Gas.....	31

Safety Information

Thank you for purchase our Thermal Mass Flow Meter. We have written this guide for correct installation, operation and maintenance.

- Please have a safe-keeping of this manual after reading.
- Please pass this manual to technical department of end user to keep it well.
- This manual classifies important grade of safety attentions by Caution and Warning.

Caution

Error operation in case of ignoring the tips might cause the personal injury, or damage to the instrument and property.

Warning

Error operation in case of ignoring the tips might cause the personal injury or major accident.

This manual contents the following icons:



Indicates safety attention where is dangerous.



Indicates safety attention where is needed to pay attention to.



Indicates safety attention which is forbidden.

Select explosion-proof instrument for explosive environment application

Confirm whether the nameplate of instrument has the identifiers of explosion-proof certification and temperature class, the instrument can't be used in explosive environment without those identifiers.

The explosion-proof temperature class of instrument must meet the explosion-proof and temperature of environmental requirements on site

When the instrument is working in explosion-proof environment, make sure that the explosion-proof certification and temperature class of instrument meet the requirements on site.

No opening while working in explosive environment

Before wiring, please power off the instrument.

The protection class of instrument must meet the working condition requirements on site

The requirement of protection class on site should be under or the same as the protection class of instrument to ensure that it could work fine.

Confirm the power type

Customer could select the power type: 220VAC or 24VDC. Please confirm the power type before installation.

Confirm the working environment of instrument and medium temperature

The environment on site and the maximum medium temperature should be under the nominal value of instrument. (The details of nominal value are shown in Part 2 Specifications.)

Confirm the ambient pressure of instrument and medium pressure

The ambient pressure on site and the maximum medium pressure should be under the nominal value of instrument. (The details of nominal value are shown in Part 2 Specifications.)

⚠ No hot-tapped installation and maintenance while pipe pressure is high

When absolute pressure of measuring medium is 5 times higher than standard atmospheric pressure, or higher than the pressure of possible danger, user should shut down or reduce pressure to reach a safe pressure class, and then do hot-tapped operation. If there are no condition for hot-tapped installation, please shut down to avoid danger.

⚠ Extra requirements of special medium

If the property of gas is special, it is needed to ordered specially, please check the manual of special product thoroughly to make sure whether it meets the requirements on site before installation.

⊘ No hot-tapped installation and maintenance while the medium is dangerous gas

If the medium may cause injury to human, please don't hot-tapped install. user should shut down or do security processing to reach a safety condition, and then do hot-tapped operation. If there is no condition to do hot-tapped operation, user should shut down to avoid dangers.

⚠ If doubt that the instrument in the event of failure, please do not operate it

If there is anything wrong with the instrument or it is damaged, please contact us.

Part 1 Introduction

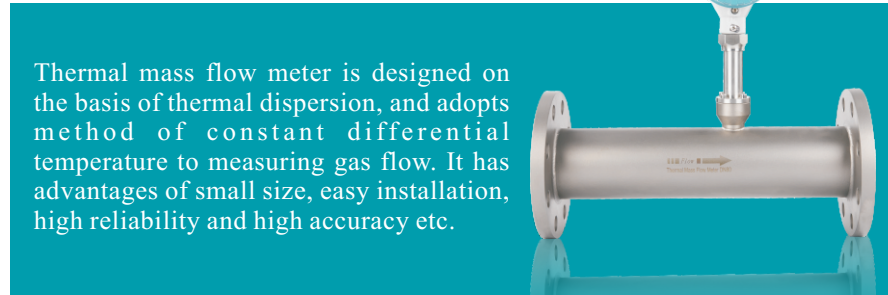

Thermal mass flow meter is designed on the basis of thermal dispersion, and adopts method of constant differential temperature to measuring gas flow. It has advantages of small size, easy installation, high reliability and high accuracy etc.

Thermal mass flow meters employ the thermal dispersion principle whereby the rate of heat absorbed by a fluid flowing in a pipe or duct is directly proportional to its mass flow. In a typical thermal flow meter gas flowing over a source of heat absorbs the heat and cools the source.

As flow increases, more heat is absorbed by the gas. The amount of heat dissipated from the heat source is proportional to the gas mass flow and its thermal properties. Therefore, measurement of the heat transfer supplies data from which a mass flow rate may be calculated.

The format of gas velocity and power consume is shown as below:

$$v = \frac{K[Q / \Delta T]^{1.87}}{\rho_g} \dots\dots\dots(1)$$

Where:

ρ_g is specific gravity of medium	V is velocity
K is balance coefficient	Q is heater power
ΔT is differential temperature	

The medium temperature range of meter is -40°C ~ 220°C. In the format (1), the specific gravity of medium is related to the density:

$$\rho = \rho_n \times \frac{101.325 + P}{101.325} \times \frac{273.15 + 20}{273.15 + T} \dots\dots\dots(2)$$

Where:

ρ_g is the medium density in working condition(kg/m^3)

ρ_n is the medium density in standard condition, 101.325kPa and 20°C (kg/m^3)

P is the pressure in working condition(kPa)

T is the temperature in working condition (°C)

It can be seen from equations (1) and (2) that the flow velocity has a certain functional relationship with the working pressure, gas density, and working condition temperature.

Since the temperature of the sensor is always automatically about 30°C higher than the temperature of the medium (environment), thermal mass flow meter does not require temperature and pressure compensation in principle.

Part 2 Specification

Features

- 01 Measure the mass flow and volume flow of gas.
- 02 No need temperature and pressure compensation in principle.
- 03 Accurate measurement and easy operation.
- 04 Wide measure range: 0.1Nm/s~100Nm/s for gas.
- 05 This flow meter also can be used for gas leak detection.
- 06 Resist vibration and long service life.
- 07 No moving part in measure tube.
- 08 Easy to install and maintain.
- 09 High accuracy and stability.
- 10 RS485 and HART communication protocol to realize automation and integration.

Description	Specifications
Measuring Medium	Various gases (Except the acetylene)
Pipe Size	DN10~DN4000mm
Velocity	0.1~100 Nm/s
Accuracy	±1.0% for inline type, ±1.5% for insertion type
Working Temp	Sensor: -40°C~+220°C Transmitter: -20°C~+45°C
Working Pressure	Insertion type: 1.6MPa Inline type: 1.0MPa, 1.6MPa, 2.5MPa, 4.0MPa
Power Supply	24VDC and 220VAC, Power consumption ≤18W
Response Time	1s
Output	4-20mA (optoelectronic isolation, maximum load 500Ω), Pulse HART (Optional)RS485 or (optoelectronic isolation)
Alarm Output	1-2 line Relay, No state, 10A/220V/AC or 5A/30V/DC
Connection Type	Flange, Thread, Tri-clamp, Insertion
Construction	Compact or Remote
Body Material	Stainless steel 304 (Standard) Stainless steel 316 (Optional)
Probe Material	Stainless steel 316L
Display	4 lines LCD. Mass flow, Volume flow in standard condition, Flow totalizer, Time, Working time, and Velocity, etc.
Protection Class	IP65

Part 3 Mechanical Construction

3.1 Appearance

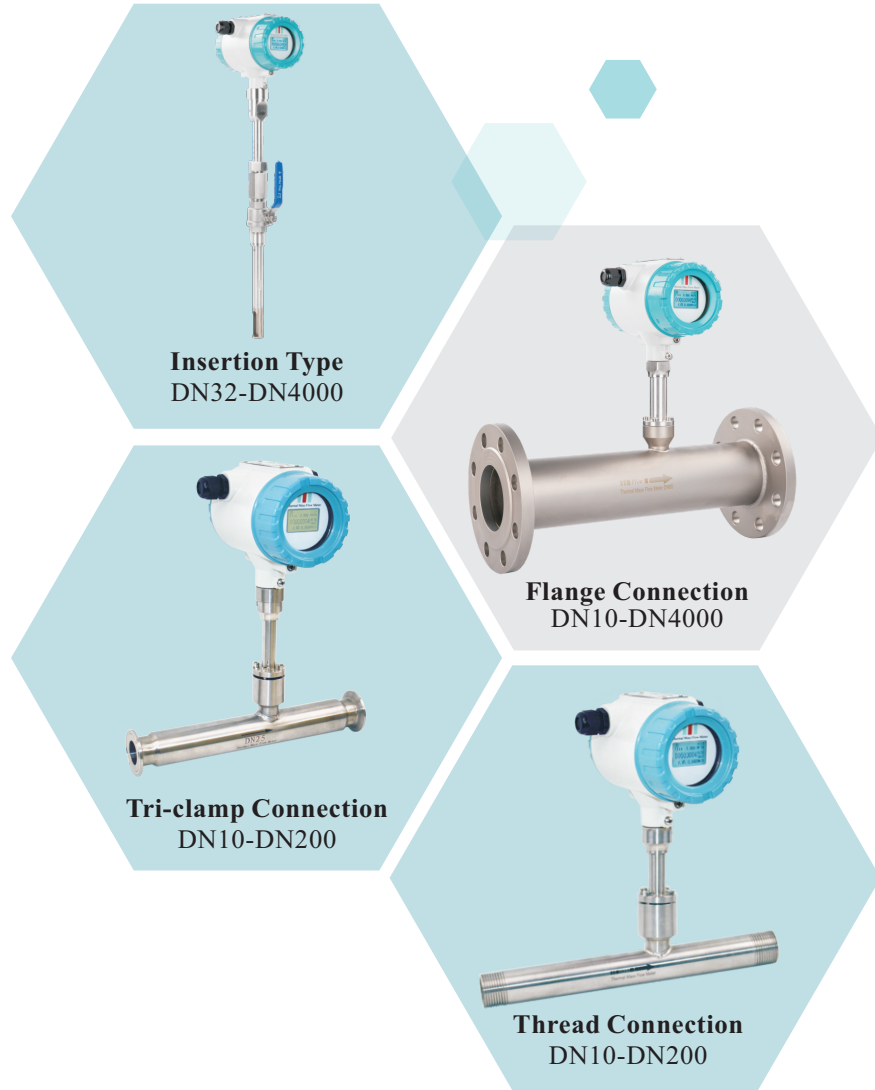

3.2 Dimension for Thermal Mass Flow Meter

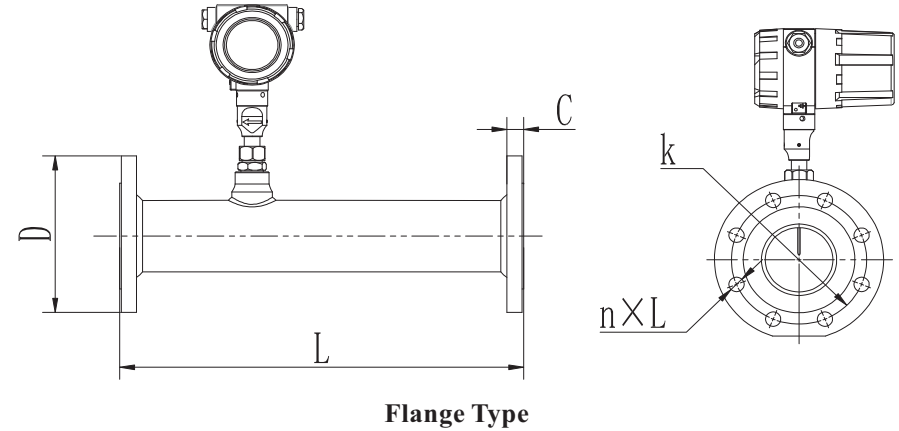

DIN PN16 Flange (Unit: mm)

Nominal Diameter	Flange Outer diameter	Center Hole	Screw Hole	Thread	Sealing Face		Flange Thickness	Pipeline Length
DN	D	k	n×L		d	f	C	L
15	95	65	4×14	M12	46	2	14	280
20	105	75	4×14	M12	56	2	16	280
25	115	85	4×14	M12	65	2	16	280
32	140	100	4×18	M16	76	2	18	350
40	150	110	4×18	M16	84	2	18	350
50	165	125	4×18	M16	99	2	20	350
65	185	145	4×18	M16	118	2	20	400
80	200	160	8×18	M16	132	2	20	400
100	220	180	8×18	M16	156	2	22	400

For DN15-DN80, thermal mass flow meter can be produced with thread connection
 Standard pressure rating is PN16, if higher rating request, please contact us for special order.

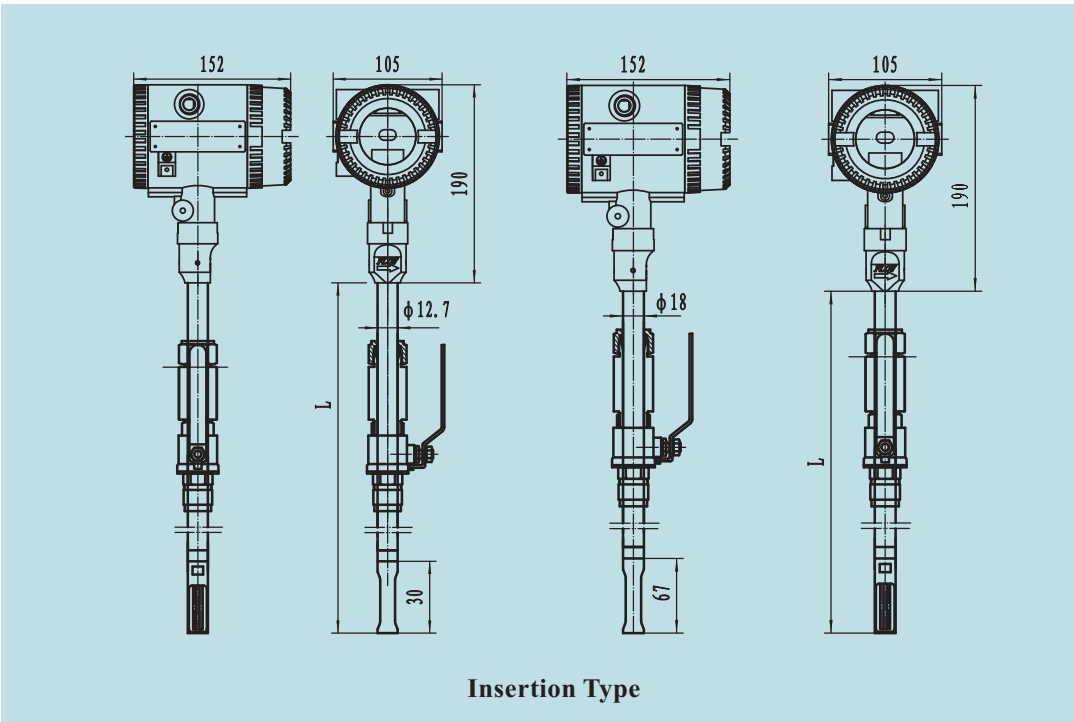

Insertion Type

Part 4 Wiring

- No wiring when the meter is working.
- Confirm the power supply type firstly.

4.1 Instruction of Sensor Wiring

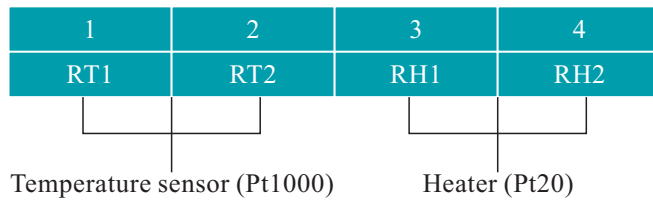

4.2 Instruction of Transmitter Wiring

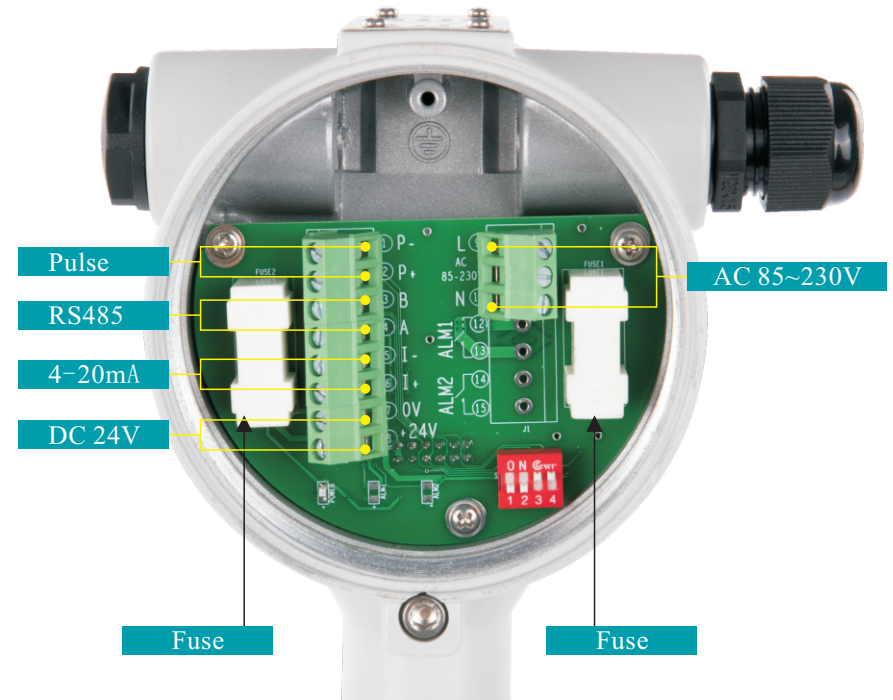

4.3 The Wiring of Power Supply

1. AC power supply

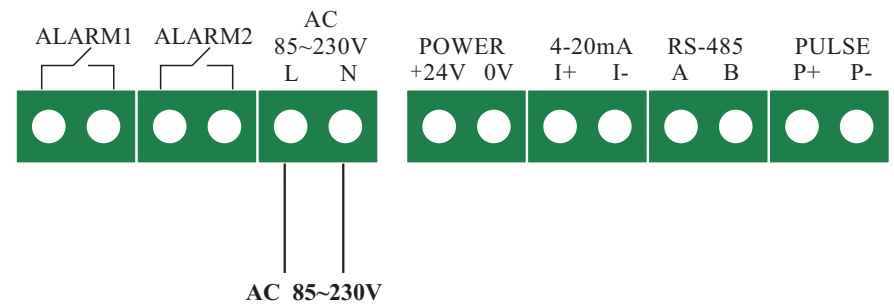

2. DC power supply

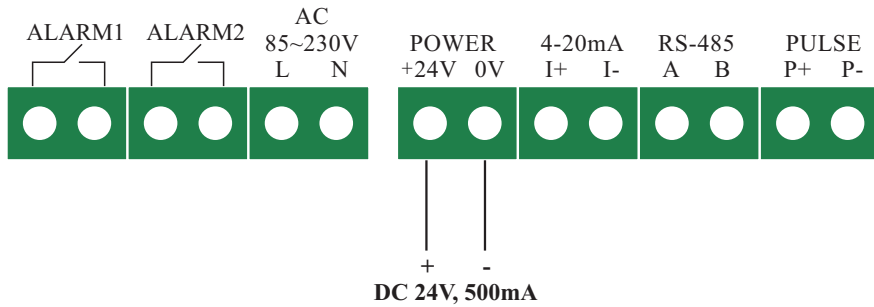

4.4 The Wiring of Output

1. The wiring of four-wire 4~20 mA output and HART operator

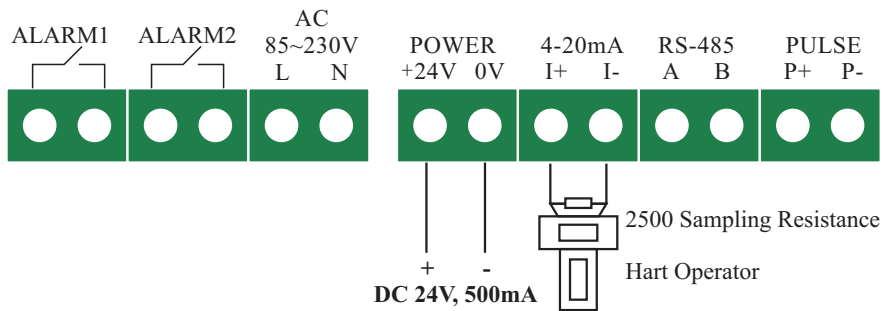

2. The wiring of RS485 output

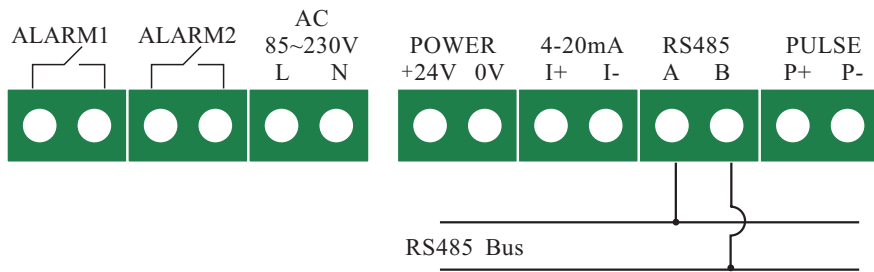

3. The wiring of pulse output

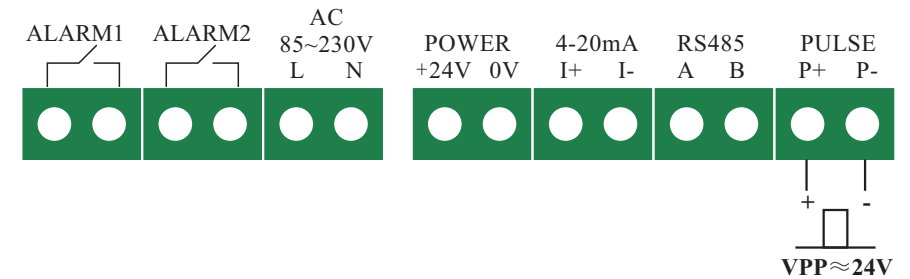

4. The wiring of alarm output

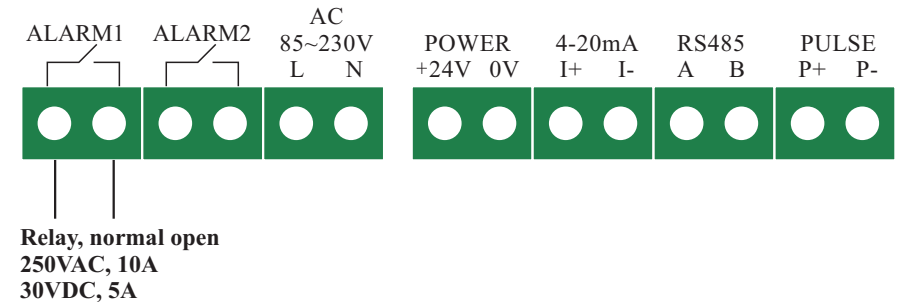

Part 5 Installation

5.1 Installation Position

Thermal mass flow meter require full pipe medium for correct flow measurement. For this reason, please note the following points when installing the device.

- Observe the recommended inlet and outlet requirements.
- Suitable engineering practice is necessary for the associated pipe work and installation.
- Ensure correct alignment and orientation of the sensor.
- Take measure to reduce or avoid condensation (e.g. install a condensation trap, thermal insulation, etc.).
- The maximum permitted ambient temperatures and the medium temperature range must be observed.
- Install the transmitter in a shaded location or use a protective sun shield.
- No installation in where large vibration exists
- No exposure in the environment containing a lot of corrosive gas

- No sharing power supply with frequency converter, electric welding machine and other machines which can make power-line interference. If necessary, please add power conditioner for transmitter power supply.

Thermal insulation

When the gas is very humid or saturated with water (e. g. Biogas), the piping and flow meter body should be insulated to prevent water droplets condensing on the measuring sensor.

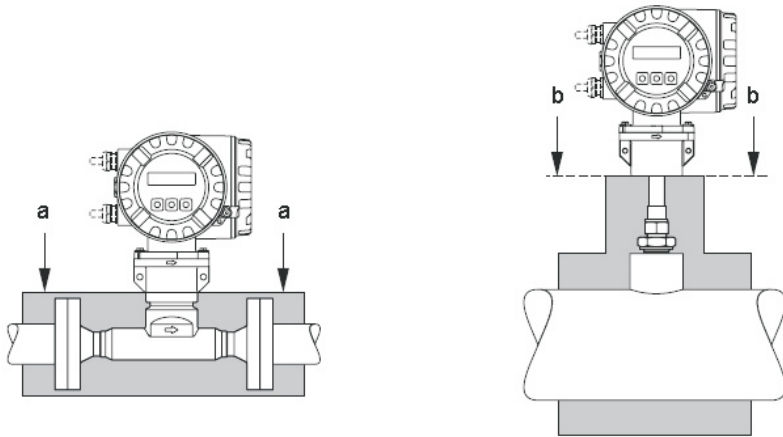

- a. Maximum insulation height for the flange sensor
- b. Maximum insulation height for the insertion sensor

The thermal dispersion principle is sensitive to disturbed flow conditions.

As a general rule, thermal mass flow meter should always be installed far away from any flow disturbance.

Where two or more flow disturbances located upstream of the meter, the recommended inlet length for the flow disturbance causing strong disturbance must be obeyed. E.g. where a valve is mounted before a bend, upstream of the flow meter, $50 \times \text{DN}$ of pipe work is required from the valve to the flow meter.



For very light gas, such as Helium and Hydrogen, all upstream distances should be doubled.

The minimum recommendations for inlet and outlet runs (without flow conditioner) are:

Flange sensor

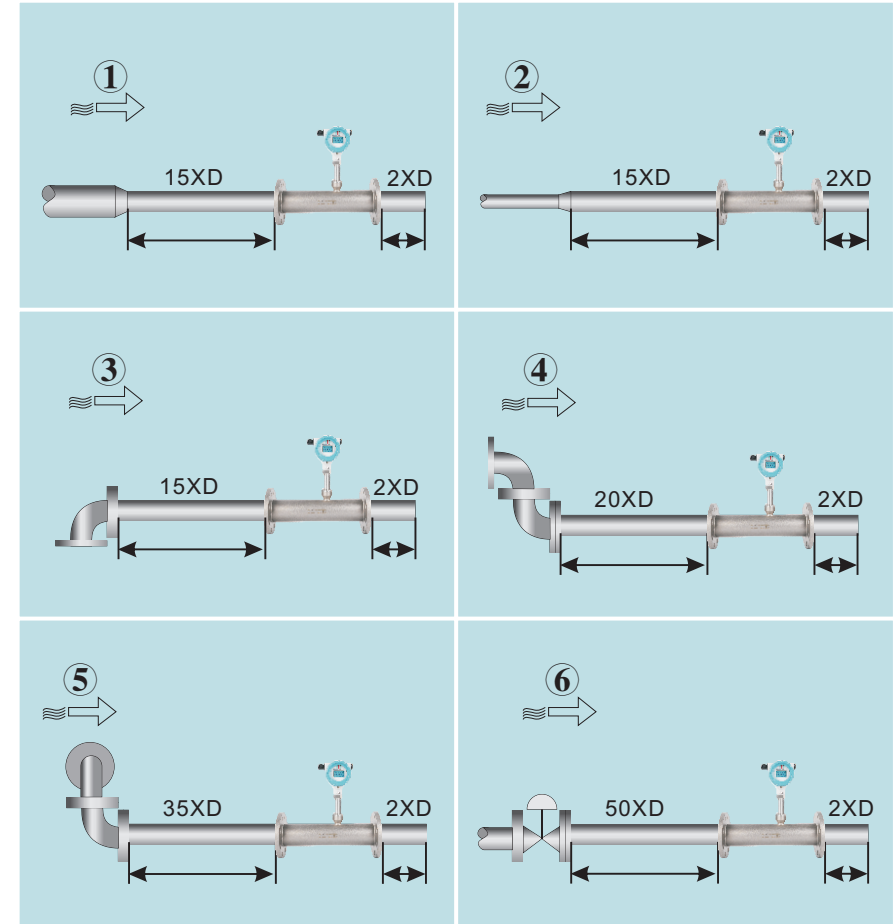

1 = Reduction

2 = Expansion

3 = 90° elbow or T-piece

4 = 2 × 90° elbow

5 = 2 × 90° elbow (three-way valve)

6 = Control valve

Insertion sensor

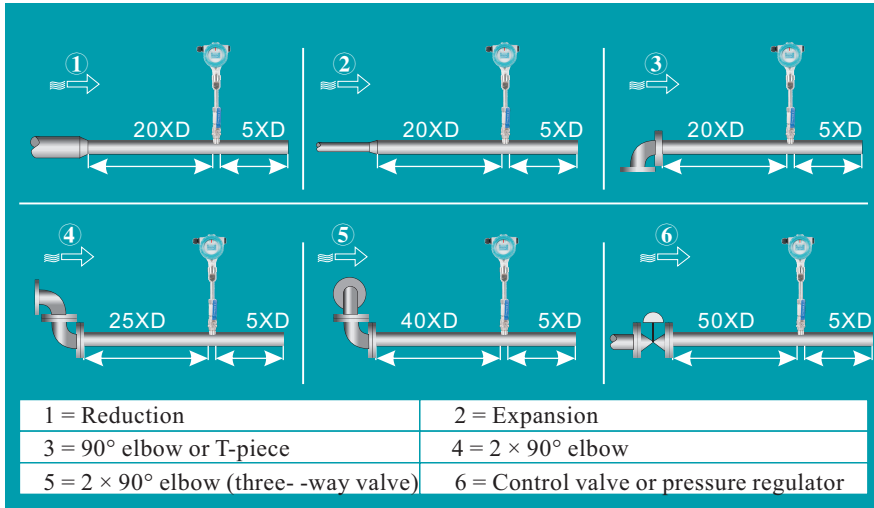

5.2 Pipework requirements

- Suitable engineering practice should be followed all the time.
- Correct preparation and welding.
- Correct sized gaskets.
- Correct aligned flanges and gaskets.
- Maximum pipe diameter mismatch should not exceed:
 - 1 mm (0.04 inch) for diameters < DN 200 (8")
 - 3 mm (0.12 inch) for diameters ≥ DN 200 (8")
- New installed thermal mass flow meter should be protected from metallic and abrasive particles which might be left in pipe.

5.3 Installation Steps

The base of thermal flow meter

- ⊘ No welding in explosive environment
- ⚠ Carry out the welding operation in accordance with the requirements of special environment.

When installing, place the base on the top of pipe, and make the axis of base be perpendicular to axis of pipe. The good welding location of base and welding process is as below.

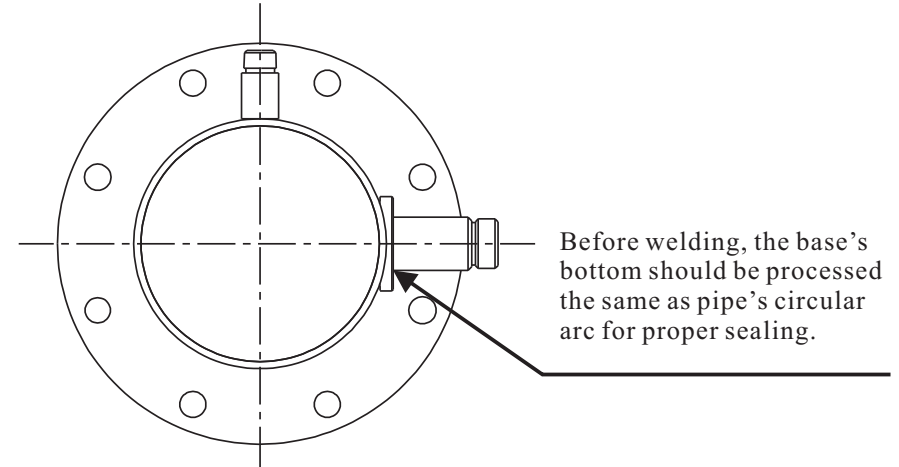

Welding location of base

The installation of standard insertion type

1. Identify an appropriate location for the flow meter.
2. Confirm the inner diameter and wall thickness of pipe
 - Place the other part of meter into ball valve, and calculate the insertion depth according to the inner diameter and wall thickness of pipe. This step doesn't need to screw the nut by hand.
 - Turn the connecting rod of sensor to make the mark direction of sensor as the same flow direction.
 - According to the calculated data on site, ensure the insertion depth by corresponding calibration on the connecting rod, and then screw the nut tightly.
 - If the meter is horizontal installation, the display of the meter can be installed in the direction of 90°, 180° or 270° to meet various requirements.

The installation of hot-tapped insertion type

- Before installation, please confirm the connection type and install fittings.
- Identify an appropriate location for the flow meter.
- According to the length requirement of flow meter, cut the pipe, and install the flanges and bolts on the pipe.

- Ensure the measure direction of flow meter is the same as flow direction, the display side is perpendicular to horizontal plane, the axis of pipeline is paralleled to horizontal plane, the error can't be more than ±2.5mm, and then fix the meter by bolts.

Part 6 Operation and Programming

6.1 Display

The display of flow meter in working status is showed as below.

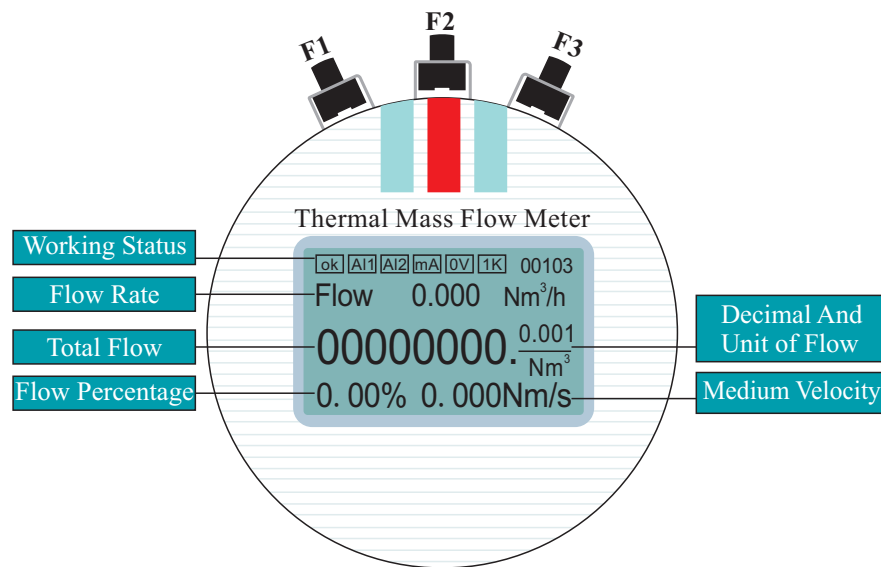

The prompt line:

OK: The meter can do self-checking. If the system is normal after self-checking, it will display OK, else it will display ERR. The error information can be checked in “Self-Test” menu.

AL1: Alarm information. AL1 means path 1 alarming, and AL2 means path 2 alarming.

mA: If the current output is beyond 20mA, it display mA, else it will be blank.

OV: If the operation parameters overflow, it display OV, else it will be blank.

1K: For convenience of display and read, when the total flow is more than 10 000 000, it display 1K, and the is the display total flow multiplied by 1000.

00103: Information of communication status. The first three digits indicate meter address, the forth digit indicates parity check (0: none; 1: odd; 2: even); and the fifty digit indicate baud rate (0: 1200, 1: 2400, 2: 4800, 3: 9600). If the meter address is 1, no parity check, and the baud rate is 9600, it will display “00103”.

After powering on, the meter will do self-checking. If the system is normal after self-checking, it will display OK, else it will display ERR. The error information can be checked in “Self-Test” set-up menu.

When the meter works fine or after powering on, the meter will do self-checking. If the system is abnormal after self-checking, the meter will display the submenu of error self-checking (Details in self test menu). 1~2 seconds later, the meter will enter the main menu automatically.

The meter has three function keys: F1, F2 and F3

F1 is Shift Key

F2 is Enter/Next Key

F3 is Modify Key

(If there are some special functions of keys, please follow the instruction below the LCD)

6.2 Parameters Setup

6.2.1 Homepage

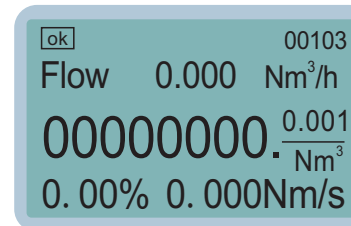

In Homepage press **F2** to enter Main menu.
In Main menu, press **F2** to enter sub- menu.

6.2.2 Main menu

```
--Main menu--
1. Display Unit
2. Self-test
3. Total reset
4. Setup
5. Calibration
6. Password
7. Record query
```

In main menu, press **F2** to enter sub-menu. **F1** could be used to move cursor from item 1 to 7.

6.2.3 Unit Display

```
Flow: Nm³/h
Total: Nm³
Temp: °C
Shift Enter Rev
```

In main menu, press **F1** to select “Unit Display”, and press **F2** to enter.

Press **F1** to select the unit of flow rate or total flow, and press **F3** to modify the unit.

Flow: The unit of flow rate. The unit can be selected as Nm³/h, Nm³/min, NI/h, NI/min, t/h, t/min, kg/h and kg/min.

Total: The unit of total flow. The unit can be selected as Nm³, NI, t and kg. Press **F2** Enter key, the main menu will display with the selected unit.

6.2.4 Self-Checking

```
Self-test
Clock ✓ Memory ✓
Power ✓ AD Con ✓
Param ✓ Amplf ✓
```

In main menu, press **F1** to select “Self-Checking”, and press **F2** to enter.

If the meter display ERR in main menu, press enter this sub-menu to check the details of running status, ✓ is ok, and × means abnormal.

After powered on, the meter will do self-checking. If there are one or more abnormal options, the meter will display the self-test menu. When the meter is working, user also can enter this menu to check the status of flow meter.

6.2.5 Total Reset

```
Total reset pwd:
000000
Shift Enter Rev
```

In main menu, press **F1** to select “Total Reset”, and press **F2** to enter. Press **F1** to type password, input reset password (default password is 000000), press **F1** to shift digit, and press **F3** to change the digit. After type password, press **F2** to enter total flow reset sub-menu.

```
Total flow reset
0000000.0000
Reset Next Reset
```

In order to prevent error operation, press **F1** and **F3** keys at the same time to do total reset. After finishing total reset, the display shows 0000000.0000. In this sub-menu, press **F2** key to enter time reset.

```
Run time Reset
00000000 min
Reset Exit Reset
```

The unit of working time is minute. The largest time is with 8 digits, and the reset operation process is the same as total reset. After reset, press **F2** key to return main menu.

6.2.6 Setup

```
Setting pwd
000000
Shift Enter Mod
```

In setup menu, press **F2** to enter. Type password (default password is 000000), press **F1** to shift digit, and press **F3** to change the digit’s number. After type password, press **F2** to finish password setup operation.

Pipe diameter
0100.000 mm
Shift Next Rev

Pipe diameter is used to input the inner diameter of pipe. The unit is mm. The range is 0000.000~9999.999. Press **F2** to enter Flow cut-off.

Flow cut-off
00000.0000Nm³/h
Shift Next Rev

Cut off the low flow according to the actual situation, and the unit is the same as flow rate. The range is 0000.0000~9999.9999. Press **F2** to Damping time.

Damping time: 00
Shift Next Rev

If the flow has a big fluctuation, increase this value to get a stable reading. The range is 0~32, 0 means no filter. Press **F2** to enter Std Density.

Std density:
1.0000 Kg/m³
Shift Next Rev

Density in Standard Condition. (20°C, 101.325KPa). That is related to flow rate display.

Medi: 00
Air
F Factor: 01.0000
Shift Next Rev

Set the medium based on the actual medium in pipe. The meter contain the medium of 59 gases, if the medium is mixed gas, it needs to calculate the factor.. The density and F Factor of common gas are shown in appendix 2. Press **F2** to enter Meter factor.

Meter factor:
1.0000
Shift Next Rev

Flow meter factor = standard flow / instrument display flow. Press **F2** to enter Full Scale Flow.

Output sel: Flow
Set scale: Nm³/h
0000000.000
Shift Next Rev

The current output type could be set in the menu: instantaneous flow and velocity of flow can be selected. The instantaneous flow unit: Nm³/h, velocity of flow unit: Nm/s. Move the cursor to the Flow, use the **F3** to modify the velocity, move the cursor by **F1** key, use **F3** key to change the value. Scale range is equal to the output of 4-20mA for flow meter. Measure scale could refer to Appendix 3. The range of effective range: 0- 9999999.999.

Device ID: 001
Baud rate: 9600
Parity: None
Shift Next Rev

RS485 communication setup. The flow meter's address range: 0~255. Baud rate can be selected 1200, 2400, 4800 and 9600. Parity check can be selected none, odd and even. Press **F2** to enter HART setup.

Polling: 00
Write Protect: N
Shift Next Rev

HART communication setup. The polling range: 00~15. Protect is "Close", the HART operator can write data; When Protect is "Open", the HART operator can't write data. Press **F2** to enter pulse output.

Pulse Out: Plus/ Equi
Freq: 0000-5000Hz
F.S: 0000100.000
Shift Next Rev

If Pulse output set as Plus, it meas Frequency output. The Frequency and scale could be set as need.

Pulse out: Equi
Unit: Nm³
Coe: 0000.0000

Shift Next Rev

If choose Equi, it means pulse output, user could set pulse unit, pulse scale as need.

Alarm 1: Flow high
S.V : +000000.000
Hyst: 000.000

Shift Next Rev

Alarm 1.
Set the alarm of Flow high, Flow low, Temp high, Temp low, Volume high, Volume low and None. S.V is used to set the alarm value. Hyst is used to prevent alarm vibration around high alarm value. The difference value can make the alarm vibration within controllable range, but this method will reduce the control precision at the same time. Set this value according to application and experience.

Alarm 2: Flow high
S.V : +000000.000
Hyst: 000.000

Shift Next Rev

Path 2 alarm. The setup is the same as alarm 1

Clock setup:
2012-05-16
09:13:29

Shift Next Rev

The date and time affect the data query and saving. Therefore, set the clock before recording data.

6.2.7 Calibration

The parameters in this sub-menu are very important. In order to prevent unauthorized operation or wrong operation, it needs to input password before entering this sub-menu.

Calibration pwd:

000000

Shift Enter Rev

In setup menu, press **F1** to select “Calibration”, and press **F2** to enter. The default password is 000000
Press **F2** to enter AD zero.

AD Zero: Measure
0.6500V
Confirm: zero flow

Shift Next EnRev

Zero voltage value is used to set the voltage value while the flow rate is 0.
Before calibration, confirm the flow in pipe is zero, and waiting for more than 30s to steady the flow. Press F1 and F3 keys at the same time until the meter displays success.
This value is can be input manually. Press F3 to select “Input”, input this value manually, and then press F2 to enter R value.
Note: Don’t input zero voltage value when flow meter is running with flow in pipe.

RC Value (0°C):
1000.000ohm

Shift Next Rev

The resistance value is used to input the resistance value of temperature sensor.
Press **F2** to enter velocity table.

Flow rate: Seq 01
Vol: 00.0647 V
F.R: 000.000 Nm/s

Shift Next Rev

Flow rate. Set the voltage and velocity in more than 40 sections.
After calibration, Input the voltage and velocity from small section to large section.
Press F2 to enter flow correction.
Note: The meter calculates the flow by velocity table. Please don’t modify the data in the table.

Flow coe: seq 0
Flow: 0000000.000
Coe: 000000.0000

Shift Next Rev

Flow correction. It can correct the flow accuracy in 5 sections based on flow speed.

I cal (Current): 4mA
Measure: 00.0000

Shift Next Rev

Current calibration. If there is deviation in current output, use this sub-menu to calibrate current output.
Press **F2** to enter zero and coefficient of current.

I Zero: +0.0000
I coe: 1.0000

Shift Next Rev

Current zero and coefficient calibration.
Note: Please don't modify these values when flow meter is running with flow in pipe.

T Zero: +0.0000
T coe: 1.0000

Shift Exit Rev

Temperature zero and coefficient calibration.
Note: Please don't modify these values when flow meter is running with flow in pipe.

6.2.8 Password

In this sub-menu, it can modify the password of total reset, setup and calibration.

Setup pwd
Total reset pwd
Calibration pwd

Shift Enter Exit

Setup pwd: Setup menu set password;
Total reset pwd: Clear total flow password;
Calibration pwd: Calibration menu password.

Setup Pwd:
Old pwd: *****
New pwd: *****

Shift Next Rev

Total reset Pwd:
Old pwd: *****
New pwd: *****

Shift Next Rev

Calibration Pwd:
Old pwd: *****
New pwd: *****

Shift Next Rev

After input old and new passwords, Press **F2** to save setup, the LCD will display "Success", and then return to main menu.

6.2.9 Query

Day Record
Month Record
Year Record

Shift Enter Rev

In setup menu, press **F1** to select "Query", and then press **F2** to enter.
In sub-menu Query, there are day, month and year records.

Day Record
2012-04-02

80.03 Nm³
Shift Next Rev

In sub-menu Query, press **F1** to select Day Record, and then press **F2** to enter.
In Day Record, press **F1** to shift cursor position, and press **F3** to modify the date.
For example, the "80.03 Nm³" is the totalizer on April 2th, 2012.
The method of checking Month and Year Records is the same as checking Day Record.

Appendix 1 Troubleshooting

Fault	Reason	Solution
No display	1. No power supply	Power on
	2. SMPS is damaged	Power on, if the power indicator light is out, it means that the SMPS is damaged, Please contact supplier.
	3. DC24V wiring connection reversed	Check the wiring, make the wiring right.
	4. The position of LCD is wrong	Re-install the LCD.
	5. The LCD is damaged	Check the power indicator light. If the light is on, it means that the LCD is damaged. Please contact supplier.
Low velocity	1. The wiring of sensor is reversed	Rewiring or re-install the sensor.
	2. The sensor is dirty	Clean sensor.
	3. The sensor is damaged	Return to supplier.
	4. Some parameters of flow setting are wrong	Check the parameters setting.
Abnormal velocity and large fluctuation	1. Some parameters of velocity setting are wrong	Check the parameters setting.
	2. Fluid properties is pulsating in turn	Adjust the system filter.
	3. The sensor is dirty	Clean sensor.
	4. The sensor is damaged	Return to supplier.

Abnormal 4-20mA output	1. The setting of 20mA range is wrong	Right settings.
	2. The Transmitter has fault	Return to supplier.
	3. The connection is not a loop circuit	Check the connection.
Abnormal frequency output	1. Some parameters of frequency setting are wrong	Right settings.
	2. The Transmitter has fault	Return to supplier.
	3. The connection cable is damaged	Change the cable.
Abnormal alarm	1. Some parameters of setting are wrong	Right settings.
	2. The meter has no alarm function	Contact supplier.
	3. The relay is damaged	Return to supplier.
Abnormal RS485 output	1. The settings of baud rate and address are wrong	Right settings.
	2. The wiring are reversed	Rewiring.
	3. The connection cable is damaged	Change the cable.

Appendix 2 The Density and Conversion Coefficient of Common Gas

At present, the laboratory cannot calibrate the flow meter according to the gas actually used by the user on working site, and the calibration is usually carried out after convert the flow medium to air. The conversion of different gases is made through the conversion coefficient, and the conversion coefficient of a single component gas can be found in the table. The following table:

Table 1 The Density and Conversion Coefficient of Common Gas

	Gas	Specific heat (Kal/g*°C)	Density (g/l, 0°C)	Conversion Coefficient
0	Air	0.24	1.2048	1.0000
1	Argon (Ar)	0.125	1.6605	1.4066
2	Arsine (AsH ₃)	0.1168	3.478	0.6690
3	Boron Tribromide (BBr ₃)	0.0647	11.18	0.3758
4	Boron Trichloride (BCl ₃)	0.1217	5.227	0.4274
5	Boron Trifluoride (BF ₃)	0.1779	3.025	0.5050
6	Borane (B ₂ H ₆)	0.502	1.235	0.4384
7	Carbon Tetrachloride (CCl ₄)	0.1297	6.86	0.3052
8	Carbon Tetrafluoride (CF ₄)	0.1659	3.9636	0.4255
9	Methane (CH ₄)	0.5318	0.715	0.7147
10	Ethylene (C ₂ H ₄)	0.3658	1.251	0.5944
11	Ethane (C ₂ H ₆)	0.4241	1.342	0.4781
12	Allylene (C ₃ H ₄)	0.3633	1.787	0.4185
13	Propylene (C ₃ H ₆)	0.3659	1.877	0.3956
14	Propane (C ₃ H ₈)	0.399	1.967	0.3459
15	Butyne (C ₄ H ₆)	0.3515	2.413	0.3201
16	Butene (C ₄ H ₈)	0.3723	2.503	0.2923
17	Butane (C ₄ H ₁₀)	0.413	2.593	0.2535
18	Pentane (C ₅ H ₁₂)	0.3916	3.219	0.2157
19	Carbinol (CH ₃ OH)	0.3277	1.43	0.5805
20	Ethanol (C ₂ H ₆ O)	0.3398	2.055	0.3897
21	Trichloroethane (C ₂ H ₃ Cl ₃)	0.1654	5.95	0.2763
22	Carbon Monoxide (CO)	0.2488	1.25	0.9940
23	Carbon Dioxide (CO ₂)	0.2017	1.964	0.7326
24	Cyanide (C ₂ N ₂)	0.2608	2.322	0.4493
25	Chlorine (Cl ₂)	0.1145	3.163	0.8529
26	Deuterium (D ₂)	1.7325	0.1798	0.9921

27	Fluoride (F ₂)	0.197	1.695	0.9255
28	Germanium Tetrachloride (GeCl ₄)	0.1072	9.565	0.2654
29	Germane (GeH ₄)	0.1405	3.418	0.5656
30	Hydrogen (H ₂)	3.4224	0.0899	1.0040
31	Hydrogen Bromide (HBr)	0.0861	3.61	0.9940
32	Hydrogen Chloride (HCl)	0.1911	1.627	0.9940
33	Hydrogen Fluoride (HF)	0.3482	0.893	0.9940
34	Hydrogen Iodide (HI)	0.0545	5.707	0.9930
35	Hydrogen Sulfide (H ₂ S)	0.2278	1.52	0.8390
36	Helium (He)	1.2418	0.1786	1.4066
37	Krypton (Kr)	0.0593	3.739	1.4066
38	nitrogen (N ₂)	0.2486	1.25	0.9940
39	Neon (Ne)	0.2464	0.9	1.4066
40	Ammonia (NH ₃)	0.5005	0.76	0.7147
41	Nitric Oxide (NO)	0.2378	1.339	0.9702
42	Nitrogen Dioxide (NO ₂)	0.1923	2.052	0.7366
43	Nitrous Oxide (N ₂ O)	0.2098	1.964	0.7048
44	Oxygen (O ₂)	0.2196	1.427	0.9861
45	Phosphorus Trichloride (PCl ₃)	0.1247	6.127	0.3559
46	Phosphorane (PH ₃)	0.261	1.517	0.6869
47	Phosphorus Pentafluoride (PF ₃)	0.1611	5.62	0.3002
48	Phosphorus Oxychloride (POCl ₃)	0.1324	6.845	0.3002
49	Silicon Tetrachloride (SiCl ₄)	0.127	7.5847	0.2823
50	Silicon Fluoride (SiF ₄)	0.1692	4.643	0.3817
51	Silane (SiH ₄)	0.3189	1.433	0.5954
52	Dichlorosilane (SiH ₂ Cl ₂)	0.1472	4.506	0.4095
53	Trichlorosilane (SiHCl ₃)	0.1332	6.043	0.3380
54	Sulfur Hexafluoride (SF ₆)	0.1588	6.516	0.2624
55	Sulfur Dioxide (SO ₂)	0.1489	2.858	0.6829
56	Titanium Tetrachloride (TiCl ₄)	0.1572	8.465	0.2048
57	Tungsten Hexafluoride (WF ₆)	0.0956	13.29	0.2137
58	Xenon (Xe)	0.0379	5.858	1.4066

Appendix 3 Upper Range Value of Common Gas

(Unit: Nm³/h. The follow table can be extended)

Nominal Diameter (mm)	Air	Nitrogen(N ₂)	Oxygen(O ₂)	Hydrogen(H ₂)
15	65	65	32	10
25	175	175	89	28
32	290	290	144	45
40	450	450	226	70
50	700	700	352	110
65	1200	1200	600	185
80	1800	1800	900	280
100	2800	2800	1420	470
125	4400	4400	2210	700
150	6300	6300	3200	940
200	10000	10000	5650	1880
250	17000	17000	8830	2820
300	25000	25000	12720	4060
400	45000	45000	22608	7200
500	70000	70000	35325	11280
600	100000	100000	50638	16300
700	135000	135000	69240	22100
800	180000	180000	90432	29000
900	220000	220000	114500	77807
1000	280000	280000	141300	81120
1200	400000	400000	203480	91972
1500	600000	600000	318000	101520
2000	700000	700000	565200	180480

The flow rate in standard condition: The flow rate is in the condition of 20°C temperature and 101.325kPa pressure.

The unit of flow rate is optional: Nm³/h, Nm³/min, L/h, L/min, t/h, t/min, kg/h or kg/min.

The reduction formula of flow rate in working condition and flow rate in standard condition:

$$Q_s = \frac{0.101325 + p}{0.10325} * \frac{273.15 + 20}{273.15 + t}$$

Qs: The flow rate in standard condition (Nm³/h).

Qn: The flow rate in working condition (m³/h).

t: The medium temperature in working condition (°C).

p: The medium pressure in working condition (Gauge pressure, Mpa).