

Pull cord switch Instruction Manual
ZAXLS-J-II

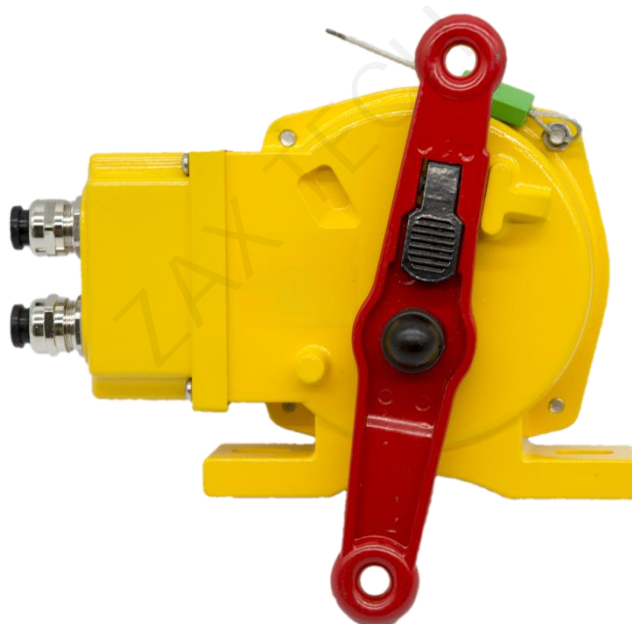

Zax Technology Co., Ltd

1. Overviews

Pull cord switch is a protection switch used for emergency stop of belt conveyor. When an emergency occurs on the belt conveyor, the staff can start the pull cord switch at any position along the conveyor and stop the belt immediately to prevent the expansion of the accident. This product is easy to install, reliable performance. It is widely used in the field of belt conveyor.

2. Characteristic

2. 1. Adopt high-strength A-alloy precise die-casting shell, with strong impact resistant capability.
 2. 2. High protective degree of shell, good sealing property.
 2. 3. Double switching output, large contact capacity, sensitive action and reliable performance.
 2. 4. Plastic coated steel wire rope moisture proof, acid and alkali resistant, flame retardant.
 2. 5. Add local junction box , easy wiring to terminals directly.
-

3. Parameter

Ambient temperature	-40°C~ 50°C
Relative humidity	0 ~ 95%
Atmospheric pressure	80 kPa ~110kPa
Designed Electrical lifespan	>100,000times
Output	2× SPDT
Contact rating	AC380V 5A DC24V 5A
Action force	70~ 100N
Adjustment range	20° ~ 30°
Angle Limit	75°
Reset mode	Manual
Protection	IP67

4. Structure features and main dimensions (mm)

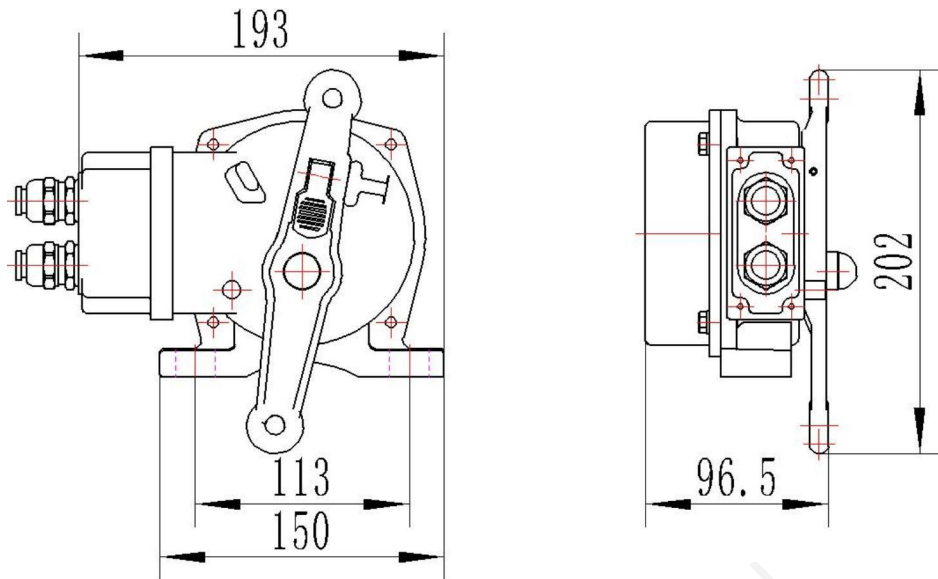

5. Installation

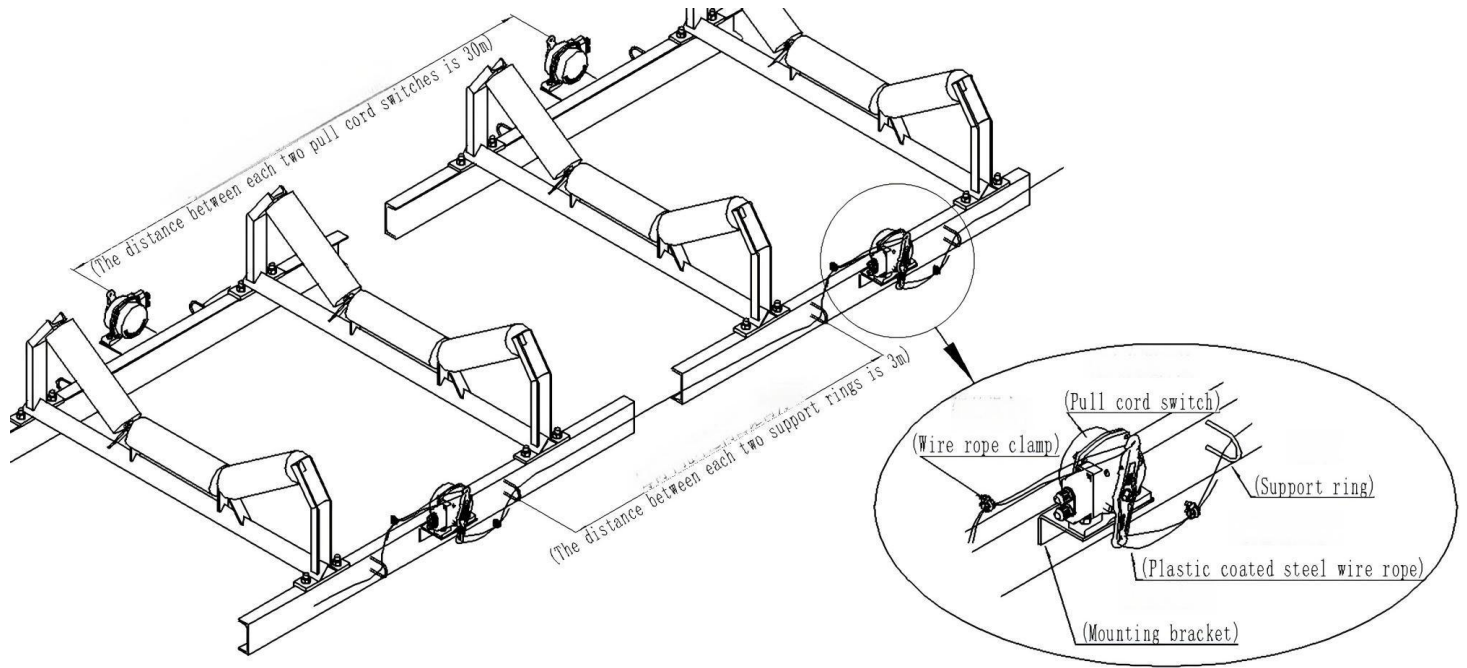

Installation diagram

6. Installation instructions

6. 1. Cautions:

6. 1. 1. Do not operation with power on.

6. 1. 2. This product is non explosion proof products, please do not use in inflammable and explosive environment.

6. 2. Materials Preparation:

6. 2. 1. Mounting bracket<Optional>

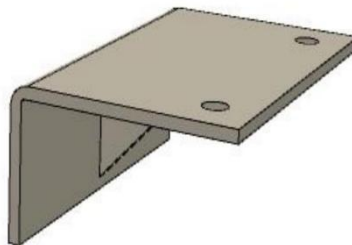

6.2.2. Pull cord switch

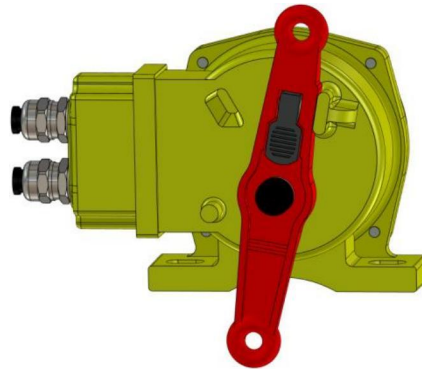

6. 2. 3. Support U-shape ring<Optional>



6. 2. 4. M10×35 Fastener × 2

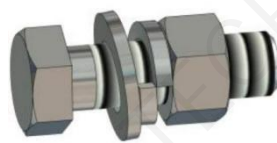

6. 2. 5. Plastic coated steel wire rope<Optional> 25-30M



6.2.6 Steel wire rope clamp



6. 3. Installation Procedure:

6. 3. 1. Fix the mounting bracket on the belt conveyor frame as shown in the figure below, and then install the pull cord switch on the bracket with fasteners.

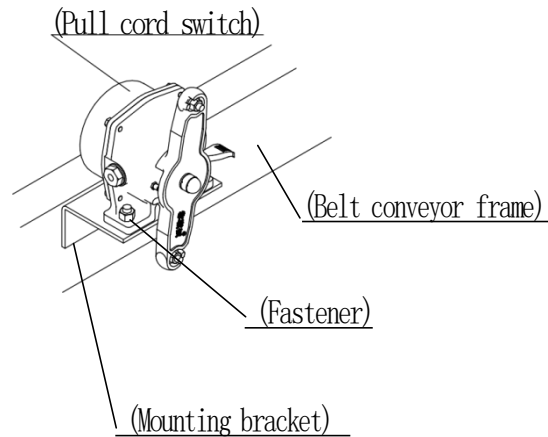

6. 3. 2. The plastic coated steel wire rope is connected to the swing arm of the pull cord switch and fixed with the hex bolt, Ensure the pull cord action is reliable. Under the premise of satisfying the normal operation of the switch, tighten the rope as much as possible to reduce the droop caused by the dead weight of the wire rope

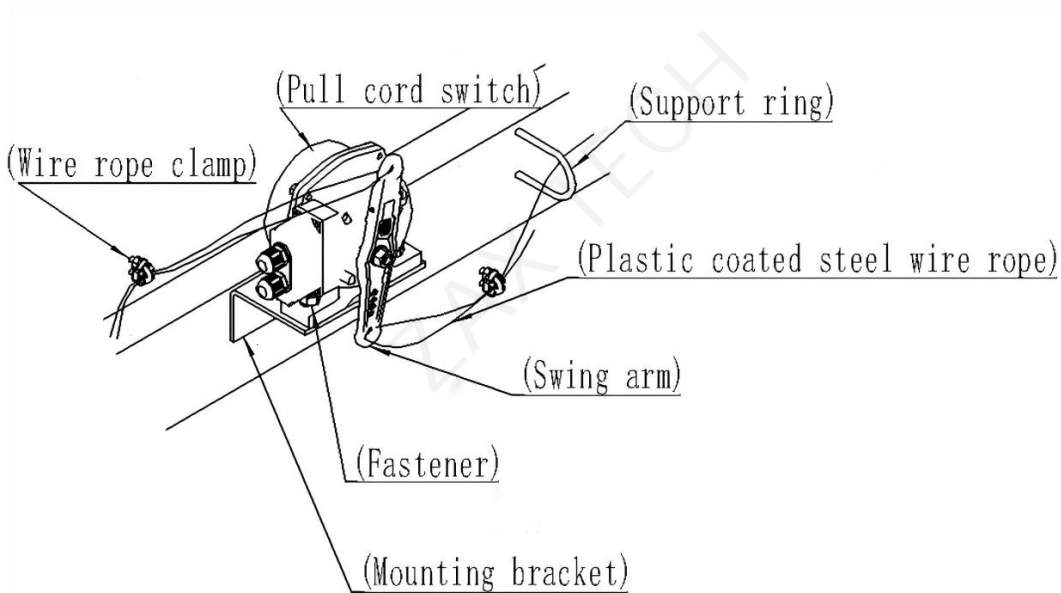

6. 3. 3. In order to reduce the influence of the dead weight of the wire rope on the switch starting, weld a support ring on the frame every 3 meters to support the wire rope.

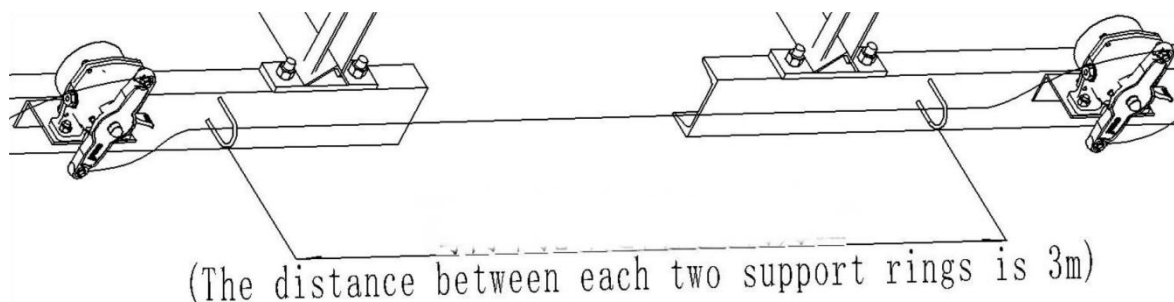

Note: The pull cord switch is installed on both sides of the frame along the belt conveyor. The distance between the two switches is 25-30 meters. The switching distance of the belt conveyor with slope should be shortened as appropriate.

6. 4. Wiring principle

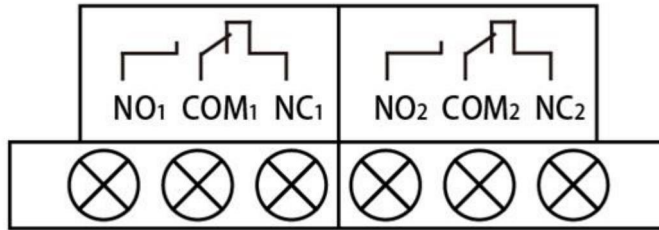

Pull cord switch wiring diagram)

7. Working principle

When an emergency occurs of the belt conveyor, the staff can pull the wire rope attached to the switch, and the wire rope can drive the swing arm to rotate, so that the stroke switch in the cable switch can act and send out the stop signal. Type I is an automatic reset mode. Type II is a manual reset mode. After troubleshooting, press the reset button to reset.

8. Maintenance

8. 1. Regular dust clean, regular check whether the switch is working properly.
 8. 2. Serious corrosion of fasteners or wire ropes should be replaced in time.
-

ZAX TECH