Instructions for Speed switch
XLDH-F-II

ZAX TECH

Zax Technology Co., Ltd

1. Overviews

The slip detector monitors the real-time speed of the driven drum in a belt conveyor to identify potential slip faults. It promptly triggers two-tiered alarm signals based on speed variations, effectively preventing losses and accident escalation. Featuring advanced ARM processor technology and embedded control principles, this product delivers stable performance, robust functionality, and high protection ratings.

2. Characteristic

- 2.1. Adopt high-strength A-alloy precise die-casting shell, with strong impact resistant capability.
 - 2.2. The surface of the shell is sprayed with plastic and has strong corrosion resistance.
 - 2.3. The shell has high protection level, good sealing, and can be used in harsh environment.
 - 2.4. Using ARM MCU as control unit, it has fast response speed, high precision and small error.
 - 2.5. Non-contact, no vulnerable components, long service life.
 - 2.6. Display via nixie tubes and LED indicator lights, facilitating on-site observation and maintenance.
 - 2.7. Integrated design with two-bolt fixation for easy installation and use.
 - 2.8. High-precision 4-20mA analog output.
 - 2.9. Output using high contact capacity relay.
 - 2.10. It has a built-in Bluetooth module, allowing users to modify parameters such as alarm points, alarm delay, and start-up delay through a mobile app.
-

3. Parameter table

Ambient temperature	-40°C~80°C
Relative humidity	0~95%
Atmospheric pressure	80 kPa ~110kPa
Working voltage	AC220V 50/60HZ
Power consumption of the whole machine	15W
Output mode and quantity	2× SPDT&1 group analog (4-20mA)
Contact rating	AC250V 3A DC30V 3A
Detection range	10~999 R/min
Optimum detection distance of sensor head	10mm
Alarm threshold value	Alarm 1 : Speed reduction 10% Alarm 2 : Speed reduction 50%
Start delay	30 S
Protection level	IP67
Display mode	3-digit LED nixie tube and indicator light
Analog quantity mode	4~20 mA
analog precision	0.1%
Analog load capacity	300 Ω

4. Structure features and main dimensions

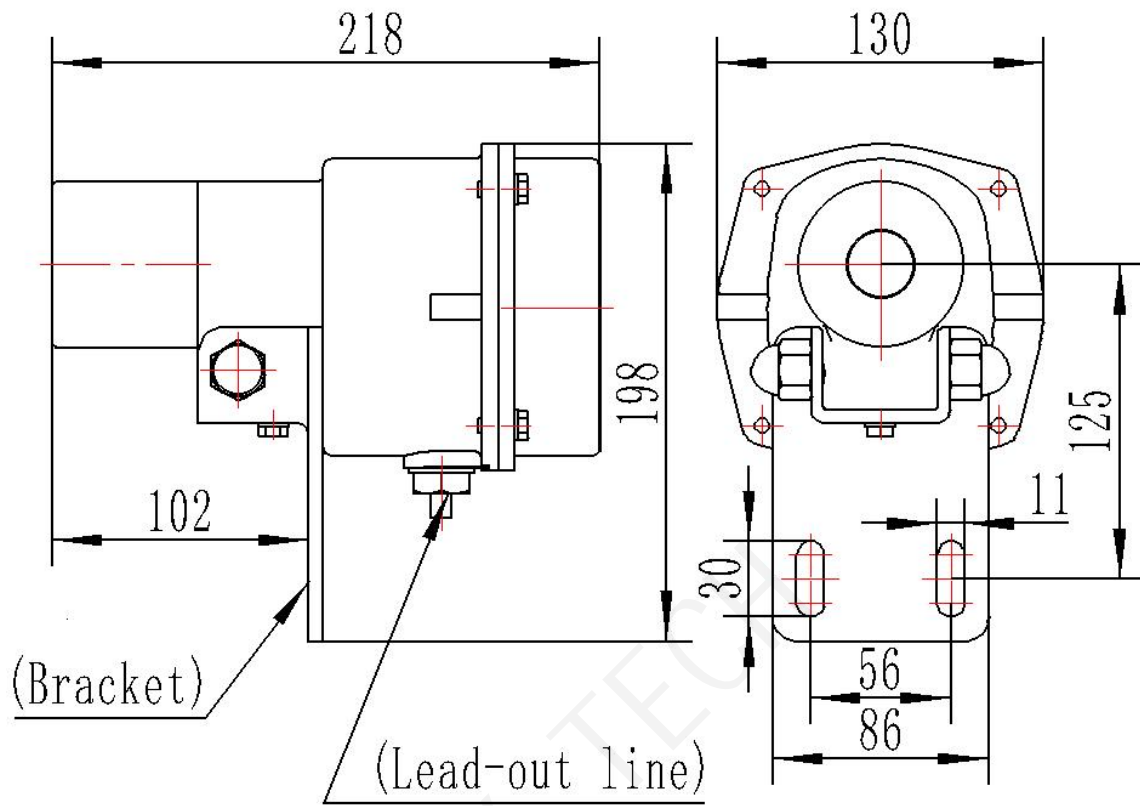

Appearance size chart(Units: mm)

5. Installation indication

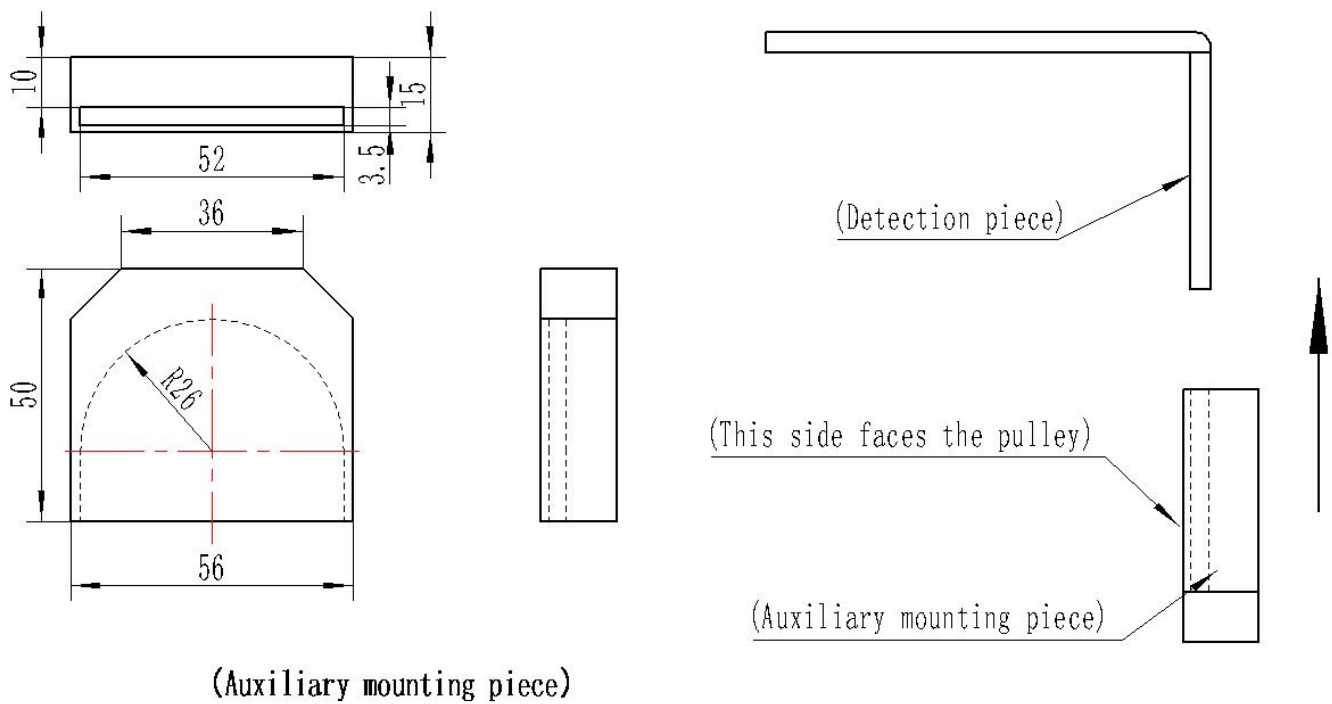

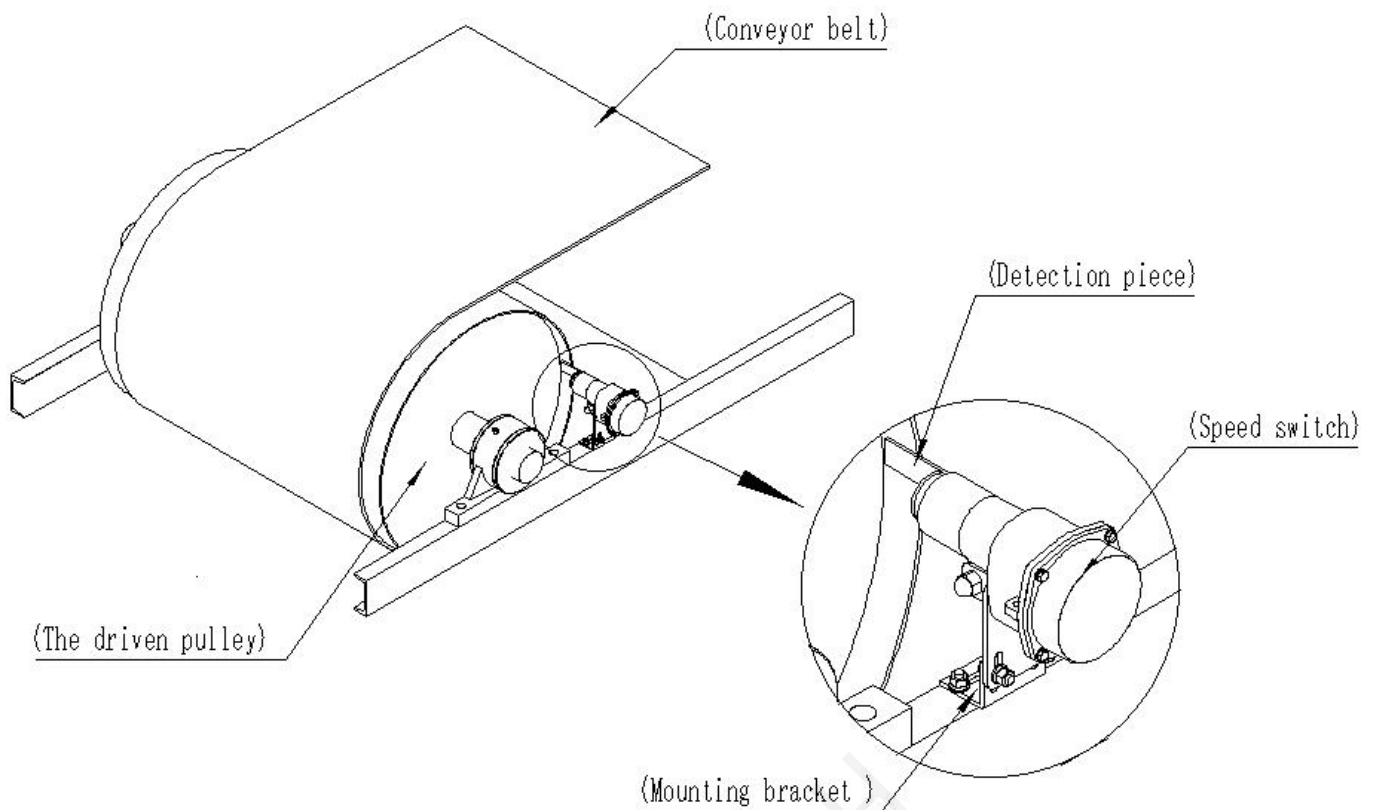

Installation indication

6. Installation instructions

6.1.Safety precautions:

6.1.1. Do not operate with electricity when installing this equipment.

6.1.2. Do not operate with electricity when installing this equipment.

6.1.3. The grounding terminal of the shell must be grounded; otherwise, the slip detector will lack protection such as lightning protection and surge protection, which will reduce its service life.

6.2.Prepare materials:

6.2.1. Install the bracket



6.2.2. Slippage detector body

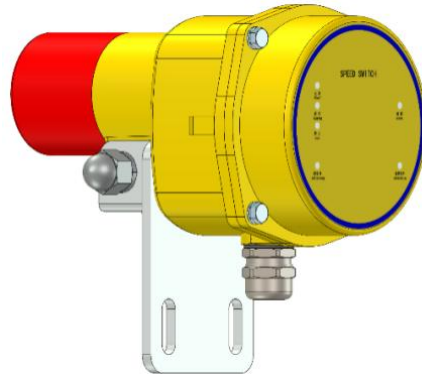

6.2.3.4 sets of fasteners (M10×35)

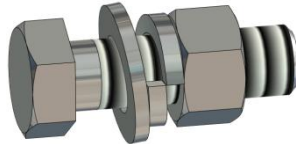

6.2.3. Detection strip



6.2.4. Auxiliary mounting block

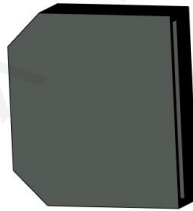

6.3. Installation steps:

6.3.1. Weld the detection piece onto the driven roller, and the distance from the edge of the detection piece to the edge of the driven roller should be greater than 25mm.

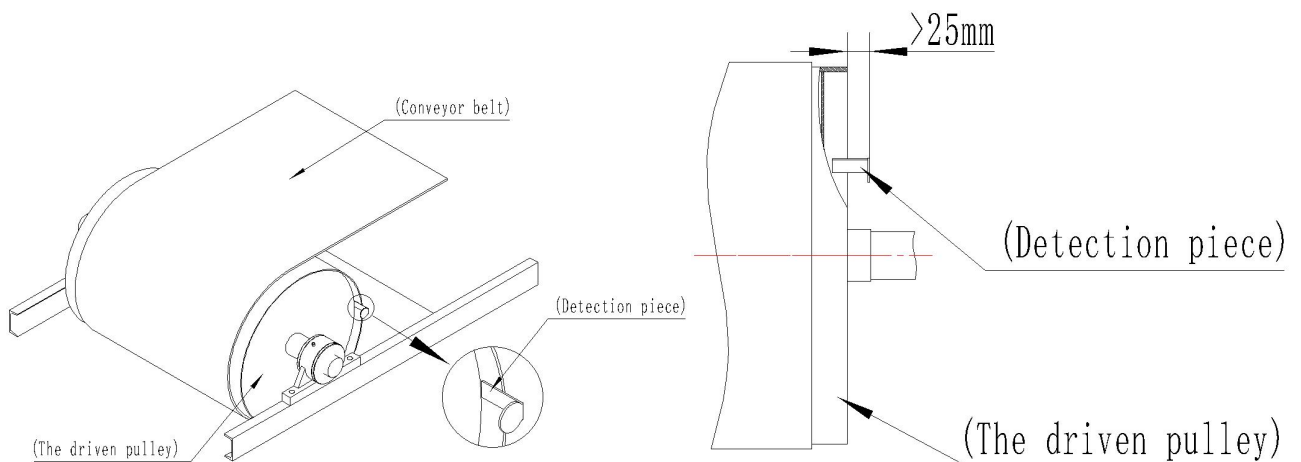

6.3.2. As shown in the figure, install the slip detector on the transport rack and fix it with fasteners.

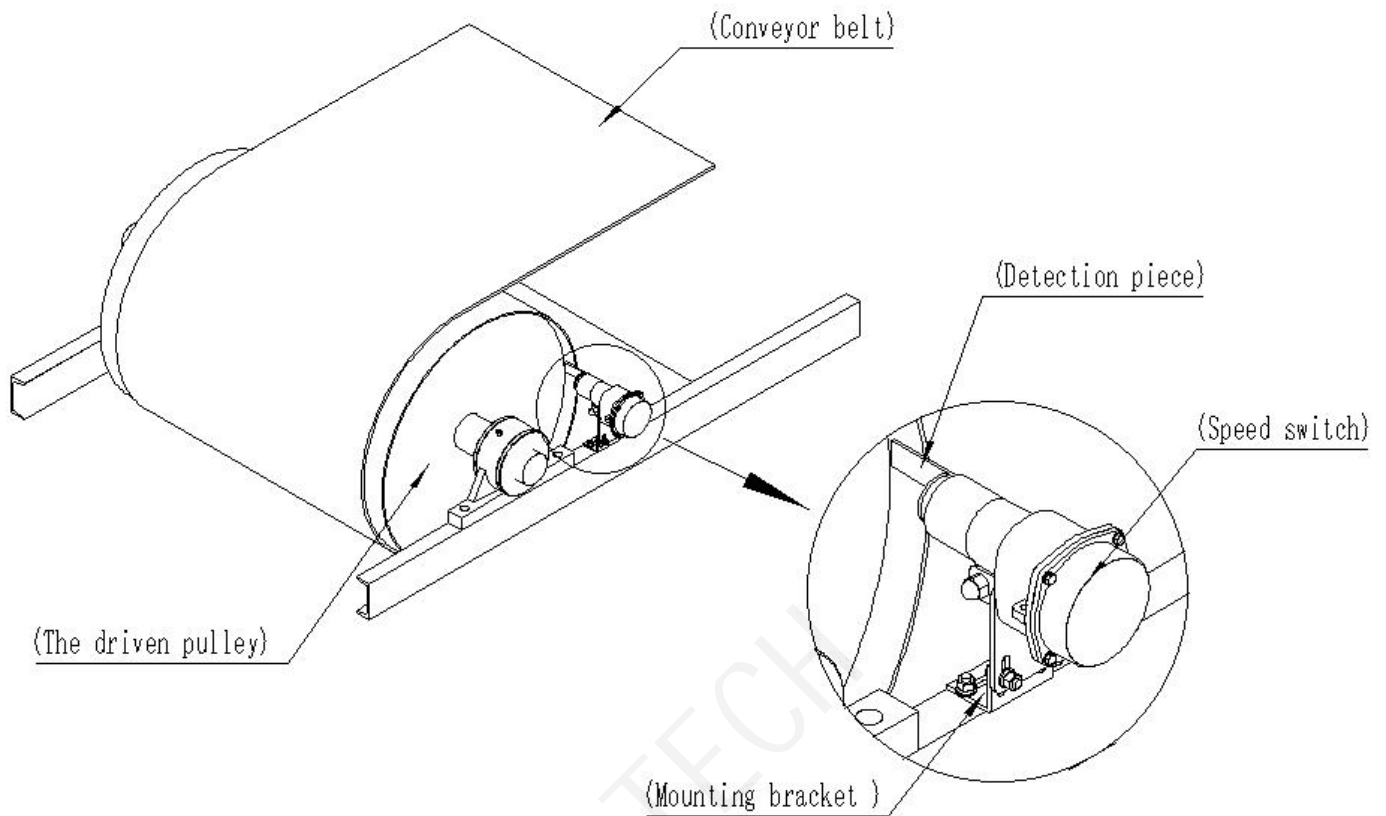

6.3.3. Put the auxiliary mounting block on the detection plate, adjust the position of the slip detector so that its sensing area is completely attached to the auxiliary mounting block, and then fix the detector with fasteners. After the installation is completed, remove the auxiliary mounting block. At this time, the distance between the sensing area of the detector and the detection plate is the optimal detection distance. 10mm.

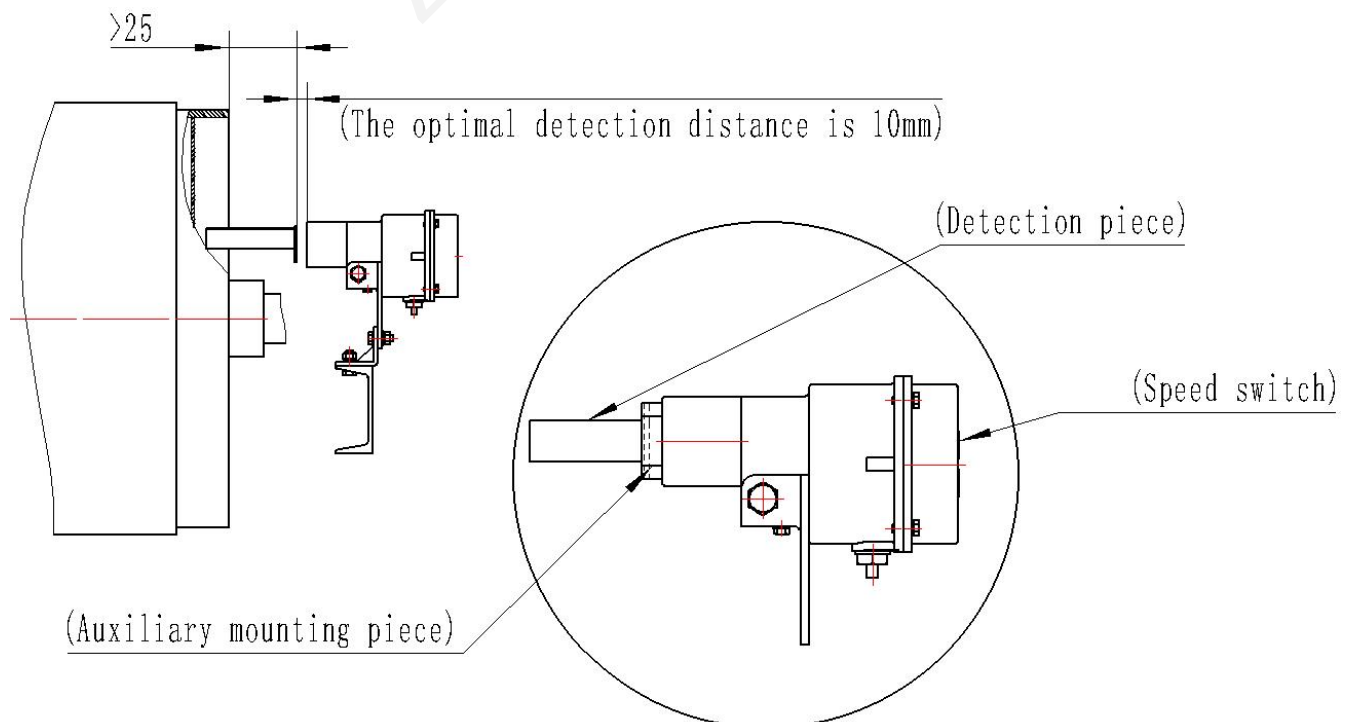

The detector should be installed on the frame near the end face of the driven roller. Each slip detector is equipped with a detection piece when leaving the factory, which must be installed at the corresponding detection position of the roller (only one detection piece can be installed at the detection position). The distance between the sensing area of the detector and the detection piece should be kept as close to 10mm as possible to ensure accurate detection.

6.4.Wiring principle

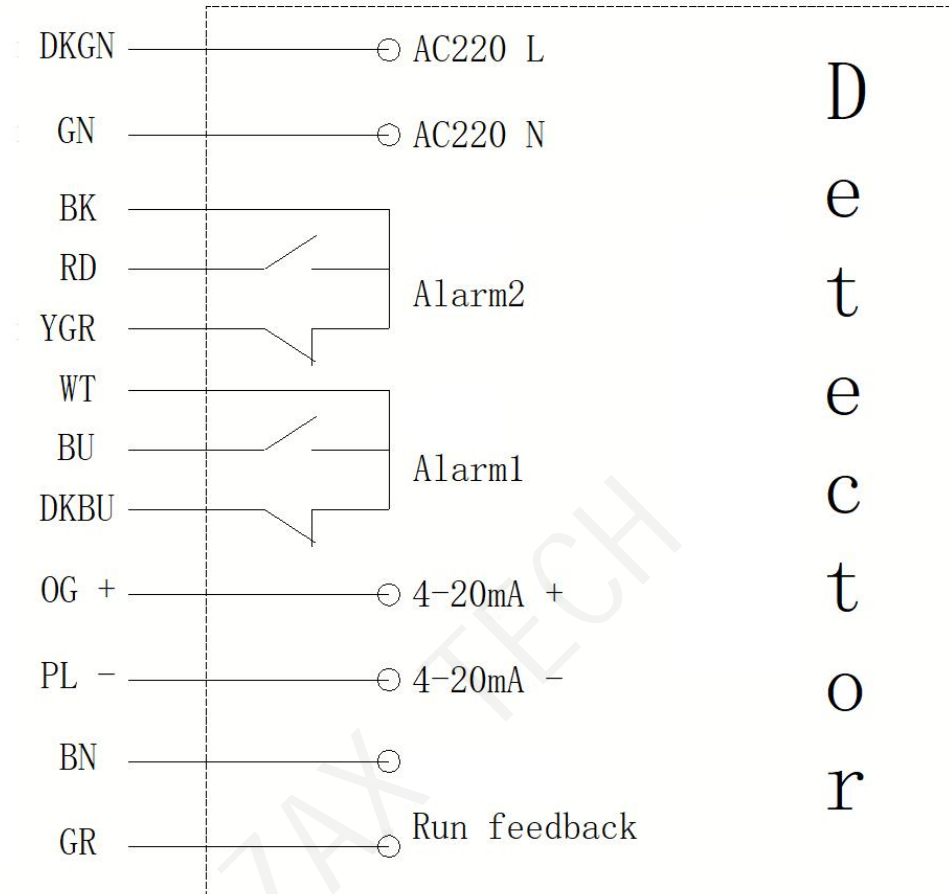

Speed switch wiring principle diagram

6.5.Definition of indicator light

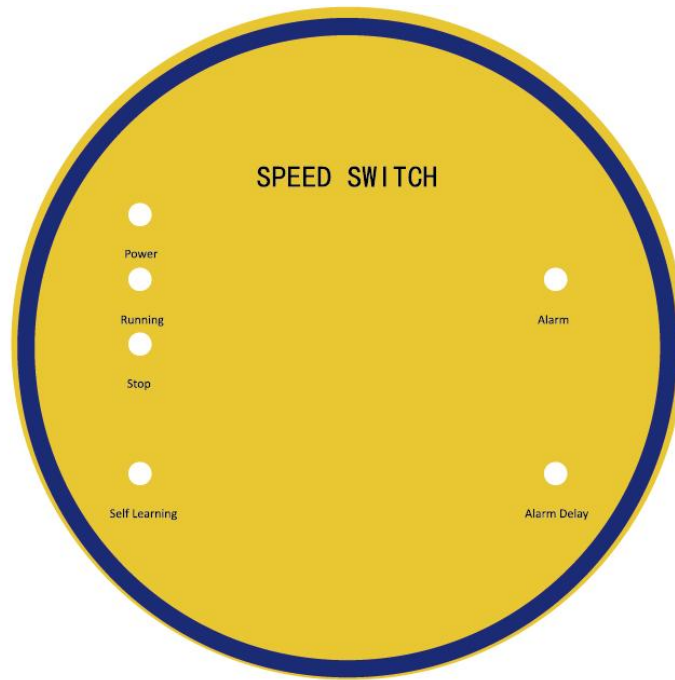

6.5.1. Operation: Blinks in learning mode, stays on after learning is completed.

6.5.2. Alarm 1: Light slip alarm indicator.

6.5.3. Alarm 2: Re-slip alarm indication.

6.5.4. Signal 1: According to the detection of the sensor input status, when the detection piece is sensed, the indicator light is on.

6.5.5. Signal 2: Belt operation feedback signal display. When the passive node of the belt operation is closed, the indicator light is on.

6.5.6. Connection: Lights up when Bluetooth is connected, otherwise turns off.

6.6. 4-20mA Meaning of analog output signal.

4-20mA The analog signal represents the belt speed change. 4mA indicates a shutdown or slip alarm state, 12mA indicates a 100% belt speed operation state, and 20mA indicates a 200% belt speed operation.

Load impedance: The analog output signal of this device can adapt to a load impedance of 0-300Ω. If the line is too long, or if it is installed together with high-voltage lines such as power lines, shielded wires must be used, and the shielding layer must be grounded.

6.7. Matters needing attention.

6.7.1. The installation distance between the sensor head and the detection plate should be as close as possible. 10mm.

6.7.2. Only one detection piece can be installed on the tested roller.

6.8. If you need to adjust the factory parameters or functions, you can connect to the device via Bluetooth by installing our company's parameter setting tool APP to perform on-site settings for the device. The parameters that can be set are shown in the table below.

Default Parameter Setting Table for Skid Detector	
1、 equipment ID	1
2、 Bluetooth address	0
4、 Display mode	rotational speed
5、 Drum diameter	0

6、 Running mode	Learning mode
7、 Standard speed	0
8、 Run feedback enabled	Disable
9、 Power-on delay	30
10、 Number of study times	10
11、 Time-limited study	30
12、 Self-reset time	0
13、 Downtime judgment time	10
14、 Learning error	5
15、 Output 1 Under-speed Threshold	10
16、 Output 1 Over-speed Threshold	0
17、 Output 1 Alarm Delay	3
18、 Output 1: Power failure alarm function	Disable
19、 Output 2 under-speed threshold	50
20、 Output 2 over-speed threshold	0
21、 Output 2 alarm delay	3
22、 Output 2: Power failure alarm function	Disable

7. Working principle

The principle that the driven roller and the conveyor belt run at the same speed is used to detect the rotational speed of the driven roller. A detection plate is installed on the inner end face of the driven roller, and a detector detects the rotational speed of the roller. When slipping occurs between the conveyor belt and the main roller, the rotational speed drops below the alarm point, and the device sends out a switch signal. Users can use this signal as an alarm or interlock signal to stop the upper conveyor or the discharge port from feeding materials to this conveyor.

Workflow: After the slip detector is powered on, it starts to determine the operating status of the conveyor belt. If the conveyor belt is in a normal operating state, the slip detector will automatically learn the standard speed of the conveyor belt after a start-up delay (default 30 seconds), which takes about 30 seconds (the learning time is related to the running speed of the conveyor belt; the faster the speed, the shorter the time). After the learning is completed, the result will be stored as a standard value, and then real-time speed detection of the conveyor belt will start, comparing it with the standard value. When the operating speed of the conveyor drops by 10% compared to the standard value, alarm 1 relay will act, and the alarm 1 indicator light will turn on; when the operating speed of the conveyor drops by 50% compared to the standard value, alarm 2 relay will act, and the alarm 2 indicator light will turn on; when the conveyor stops running, both alarm 1 relay and alarm 2 relay will act simultaneously, and both alarm 1 indicator light and alarm 2 indicator light will turn on at the same time.

The default "self-reset time" is 0. In this state, when the slip detector detects that the conveyor has stopped, Alarm 1 and Alarm 2 will output continuously. Only when the slip detector detects the conveyor starting again will the Alarm 1 and Alarm 2 relays of the slip detector cancel immediately. After the slip detector is powered on, if the belt does not run and the start delay of 30 seconds is exceeded, the slip detector will alarm (learning failed), and the Alarm 1 relay and Alarm 2 relay will act simultaneously, while the Alarm 1 indicator light and Alarm 2 indicator light will turn on at the same time.

If the "self-reset time" is not 0, in this state, after the slip detector detects that the conveyor has stopped, alarm 1 and alarm 2 will be automatically released and the indicator light will go off after a delay of the set seconds. After the slip detector is powered on, it will enter the self-learning state only when a pulse is detected; if no pulse is detected, the slip detector will remain in the waiting state.

8. Parameter setting tool APP

8.1. First, contact the company, download the software installation package at the designated location, and install it (the APP only supports the Android system).

8.2. Turn on the Bluetooth and location services on your phone. After entering the homepage of the software, select "Skidding" in the first drop-down box, select "Display only skidding" in the second drop-down box, and click the search button; select DXDH-0 and click the connect button.

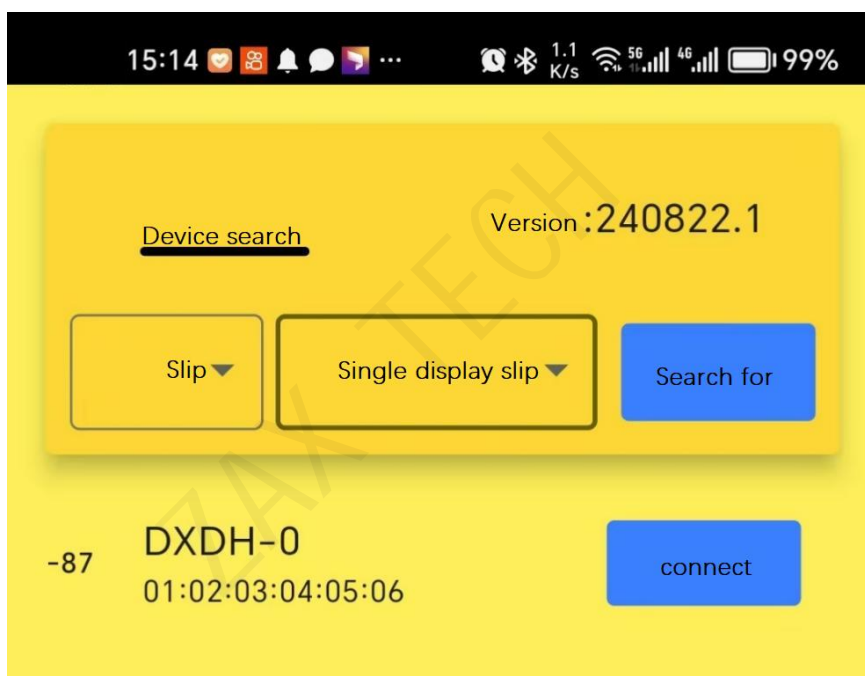

8.3. Click the parameter button below to enter the parameter settings interface, click the parameter you want to modify to make changes, and after completing the modification, click the save button on the right.

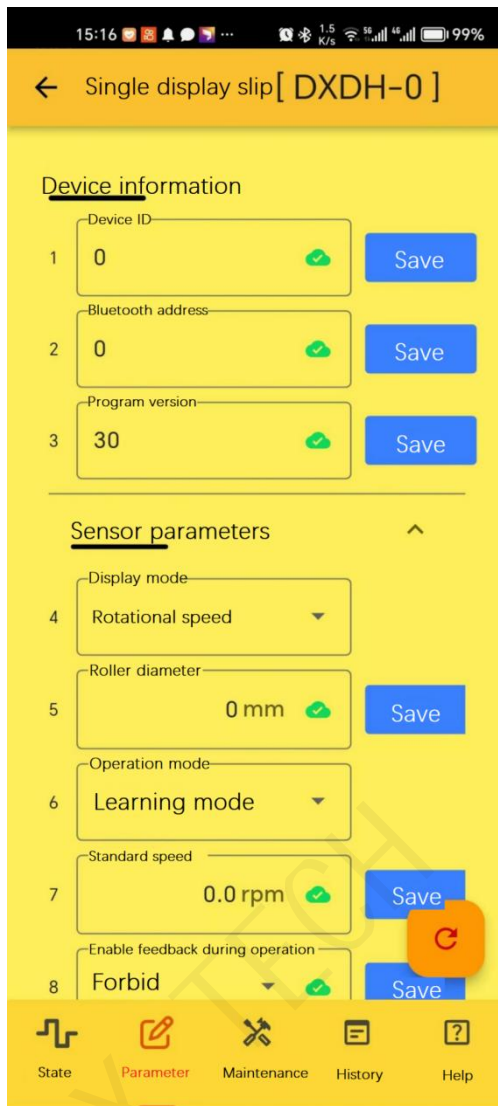

8.4. After modifying the parameters, scroll down to the bottom, click the "Save and Restart" button to complete the parameter modification.

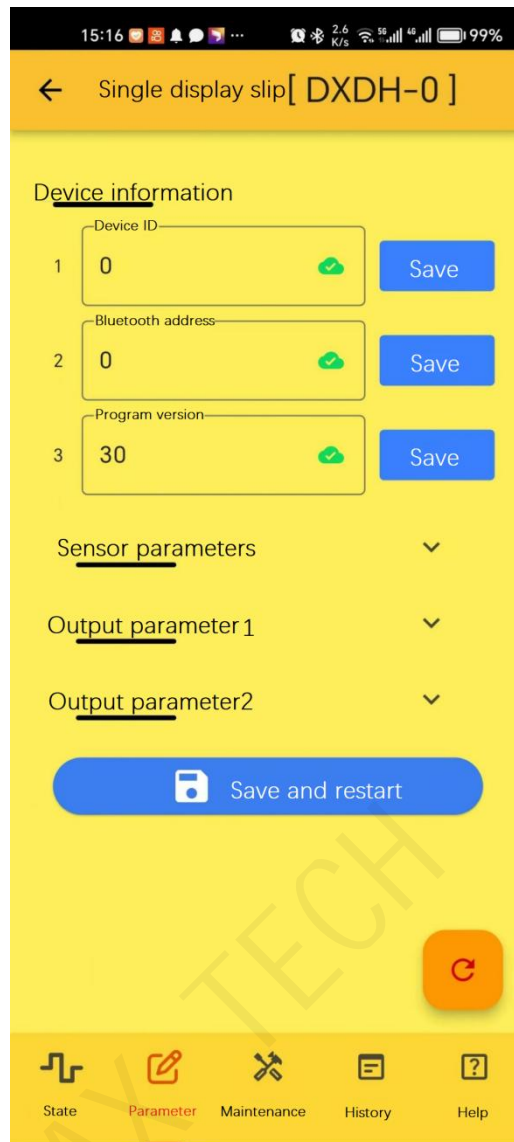

8.5. The meaning of APP parameters can be understood by clicking the help button.

9. maintenance

9.1. Frequently check whether the distance between the sensor and the detection piece is normal.

9.2. Check whether the detector mounting bracket is firm and reliable.