

Instructions for Belt sway switch
ZAXPP -I V1.0

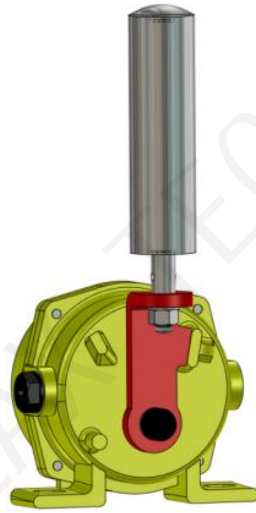

Zax Technology Co., Ltd

1. Overviews

Belt sway switch can prevent material overflow or belt damage caused by belt sway by detecting the belt. This product is easy to install, reliable performance, It is widely used in the field of belt conveyor.

2. Characteristic

- 2.1. Adopt high-strength A-alloy precise die-casting shell, with strong impact resistant capability.
 - 2.2. Adopt two-level action mode of light sway and heavy sway.
 - 2.3. The shell has high protection level, good sealing, and can be used in harsh environment.
 - 2.4. Large contact capacity, sensitive action and reliable performance.
-
-

3. Model

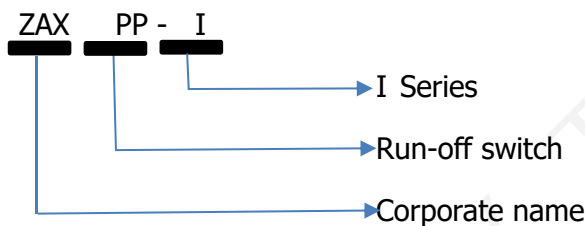

4. Parameter table

Ambient temperature	-40°C~50°C
Relative humidity	0~95%
Atmospheric pressure	80 kPa ~110kPa
Electrical life	>100,000times
Output mode and quantity	2×SPDT
Contact rating	AC380V 5A DC24V 5A
Action force	75~100N
First-level action angle	15°
Second-level action angle	30°
Limit angle	75°
Reset mode	Automatic
Protection level	IP67

5. Structure features and main dimensions

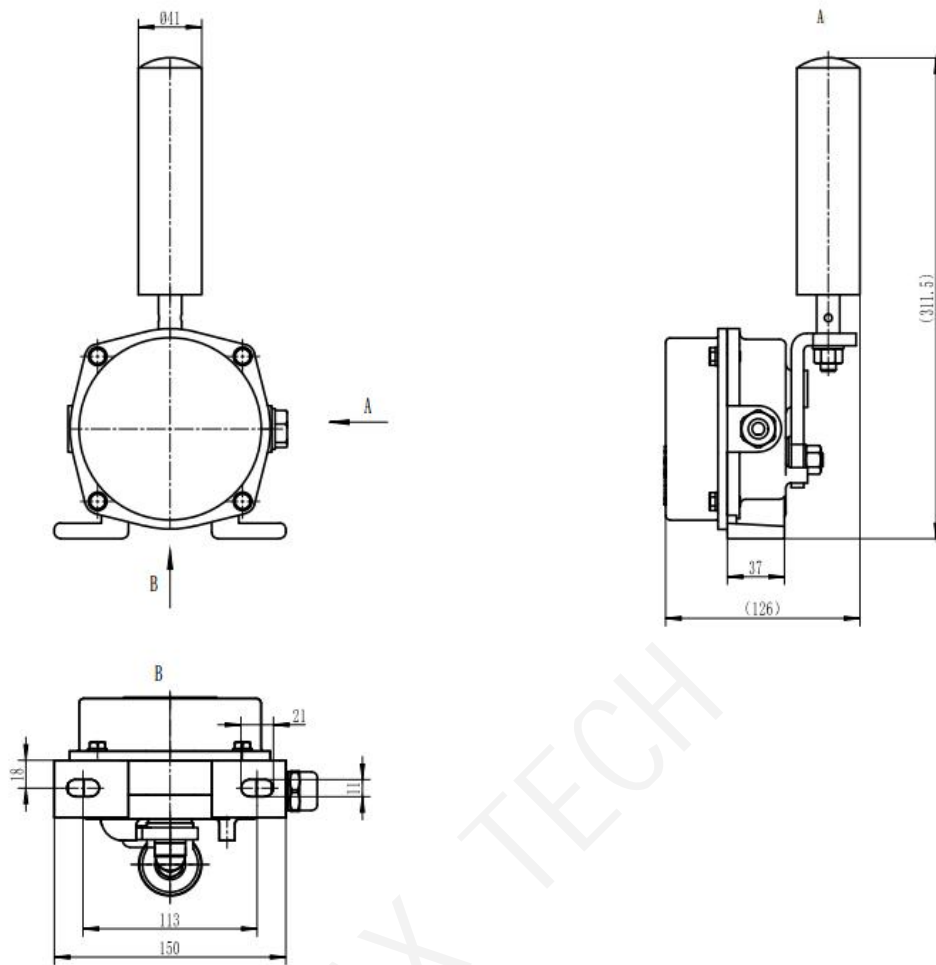

Appearance size chart (Units: mm)

6. Installation indication

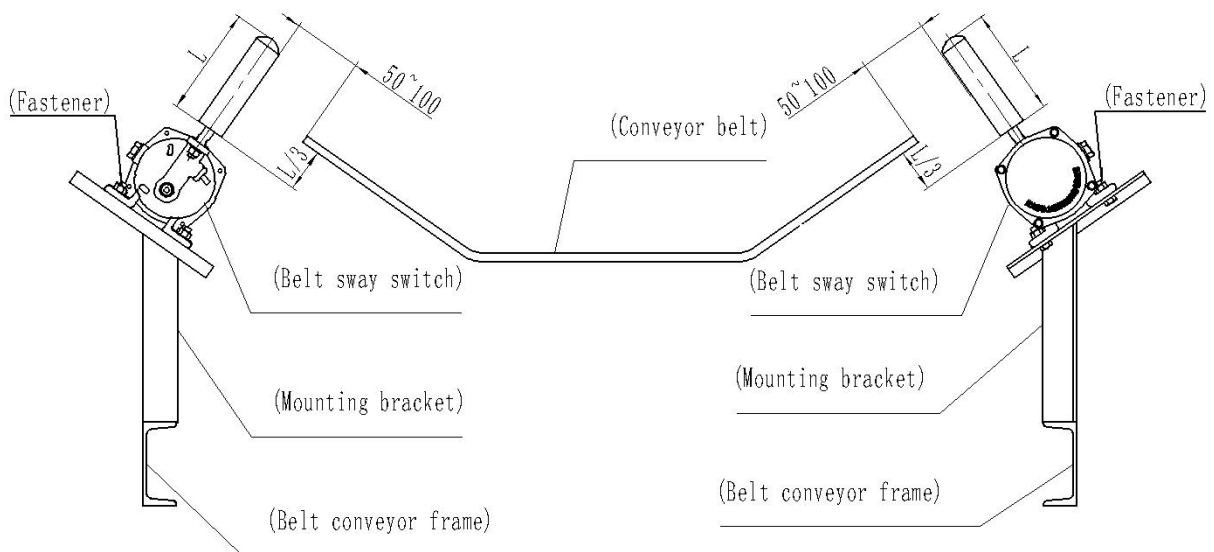

Installation indication diagram

7. Installation instructions

7.1. WARNING :

7.1.1. Do not live operation.

7.1.2. This product is non explosion proof products, please do not use in inflammable and explosive environment.

7.2. Prepare materials :

7.2.1. Mounting bracket <Purchase separately> × 2



7.2.2. Belt sway switch × 2

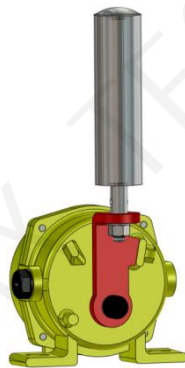

7.2.3. Fastener × 4 (M10×35)

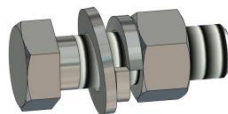

7.3. Installation steps :

7.3.1. Weld the two mounting brackets parallel to the belt conveyor frame as shown in the figure below.

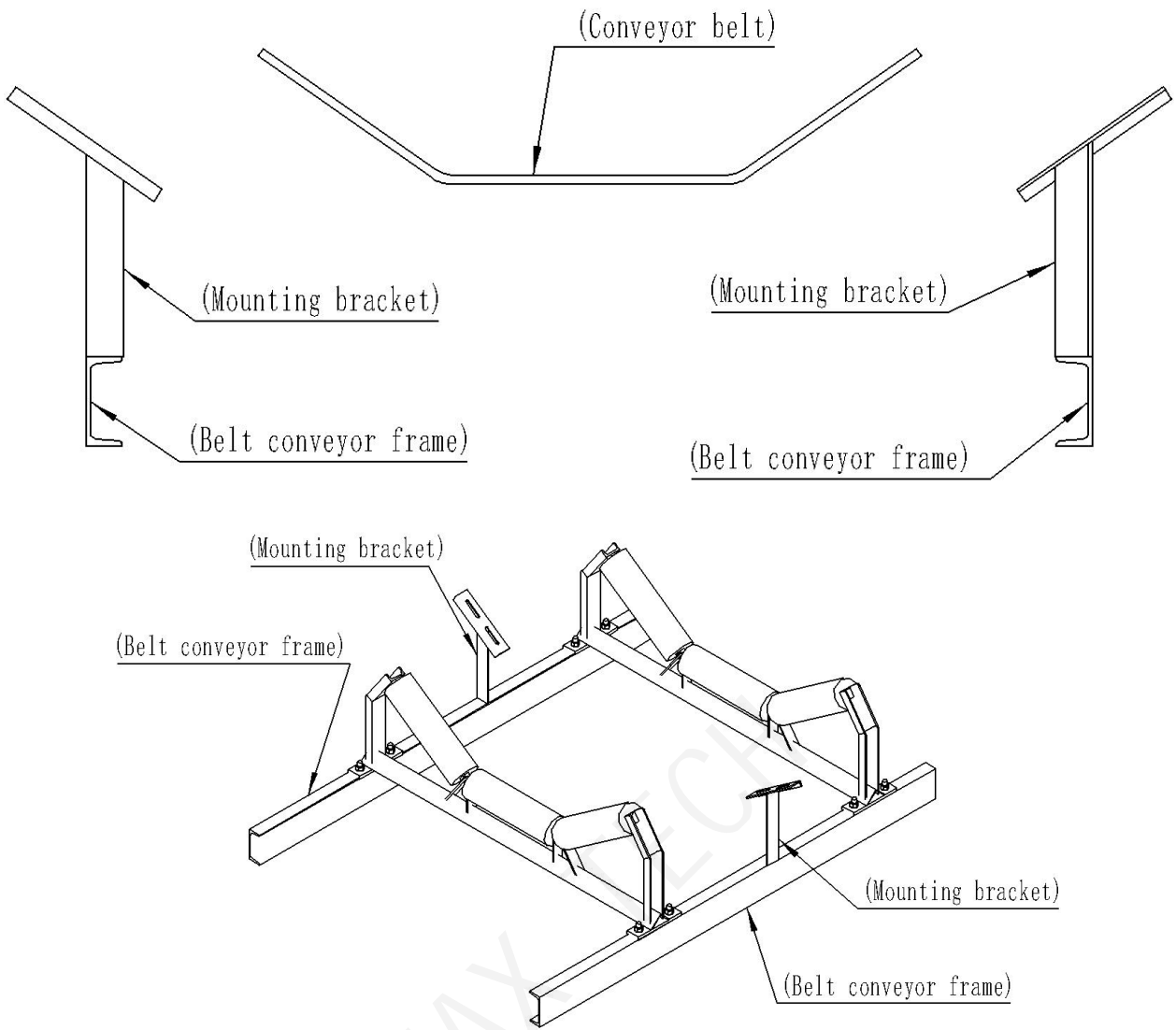

7.3.2. The belt sway switch shall be installed on the mounting bracket in pairs. The position of the vertical roll shall be perpendicular to the plane of the belt edge, and the belt edge shall be guaranteed to be located at one third of the height of the vertical roll. The distance between the vertical roll and the belt edge shall be 50-100 mm. Then fastened with fastener.

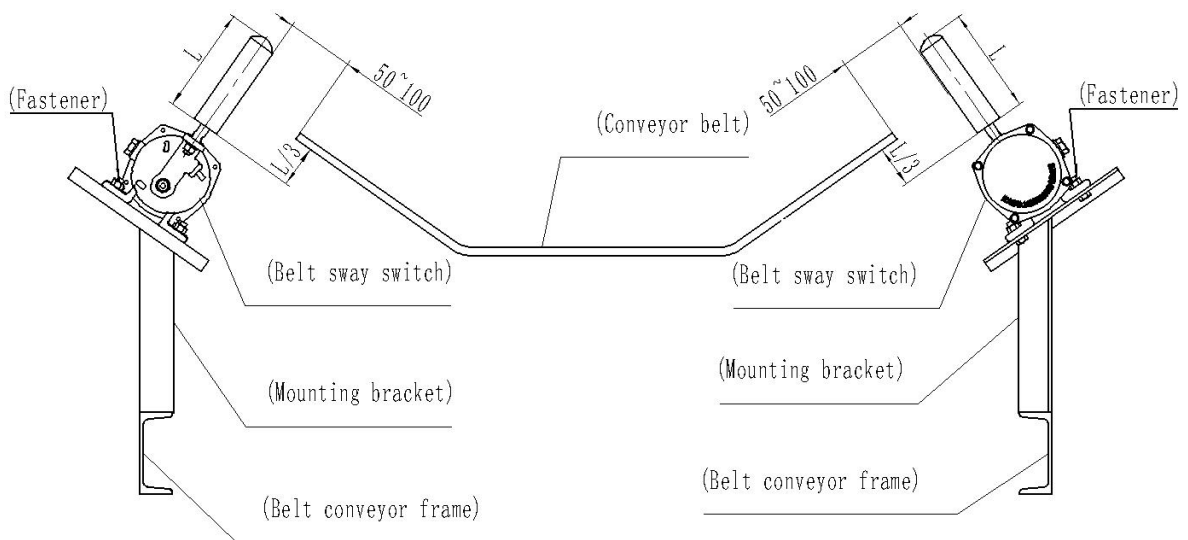

7.3.3. The belt sway switch shall be installed in pairs at the head and tail of the belt conveyor. One pair of belt sway switch (2 sets) shall be installed at 50 m interval of the belt.

7.3.4. Wiring principle

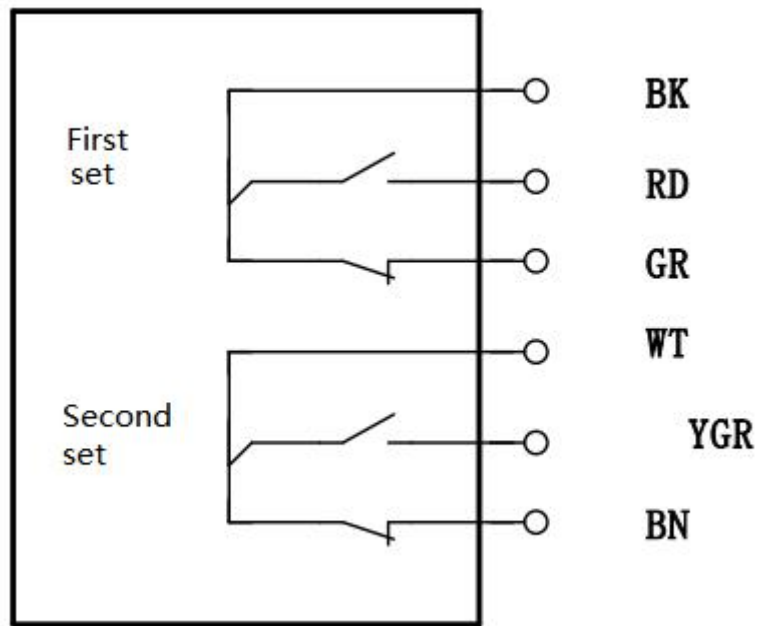

Belt sway switch wiring diagram

8. Working principle

When the running conveyor belt deviates, the edge of the conveyor belt drives the vertical roll to rotate and extrudes the vertical roll to make it tilt. If the tilt angle of the vertical roll is greater than the first action angle of the switch, a set of switch signals will be sent out immediately; if the vertical roll continues to tilt more than the second action angle, another set of switch signals will be output. Two sets of switch signals can be used for alarm or shutdown respectively. After the conveyor belt deviate fault returns to normal, the vertical roll automatically resets.

9. Maintain

- 9.1. Regular dust removal, regular check whether the switch is working properly;
 - 9.2. Check regularly whether the belt sway switch vertical roll is flexible.
-